

Reg. No.

--	--	--	--	--	--	--	--	--	--	--	--	--	--	--	--	--	--	--	--

**Question Paper Code : 91626**

B.E./B.Tech. DEGREE EXAMINATION, NOVEMBER/DECEMBER 2014.

Second Semester

Civil Engineering

ME 2151/ME 25/080120002/CE 1151/10122 ME 205 — ENGINEERING  
MECHANICS

(Common to Aeronautical, Automobile, Marine, Mechanical, Production, Chemical, Petroleum Engineering, Biotechnology, Polymer, Textile, Textile (Fashion), Plastic Technology, Materials Science and Engineering, Manufacturing Engineering, Mechatronics Engineering, Industrial Engineering, Industrial Engineering and Management, Environmental Engineering, Geoinformatics, Mechanical and Automation Engineering, Petrochemical Engineering, Chemical and Electrochemical Engineering, Petrochemical Technology, Pharmaceutical Technology, Textile Chemistry and Mechanical Engineering (Sandwich))

(Regulation 2008/2010)

(Common to 10122 ME 205 – Engineering Mechanics for B.E. (Part–Time)  
First Semester – Mechanical Engineering – Regulation 2010)

Time : Three hours

Maximum : 100 marks

Answer ALL questions.

PART A — (10 × 2 = 20 marks)

1. State Lamé's theorem.
2. What is coplanar concurrent force system?
3. State Varignon's theorem
4. A rigid body is in equilibrium under the action of three coplanar forces. State the condition of forces.
5. State perpendicular axis theorem
6. How the mass moment of inertia of a rectangular plate is related to the area moment of inertia of the rectangle about an axis?
7. Distinguish between uniform motion and uniformly accelerated motion.

8. What is Work - Energy Principle?
9. What is rolling resistance?
10. What is general plane motion? Give examples.

PART B — (5 × 16 = 80 marks)

11. (a) ABCD is a square, forces 2 kN, 3 kN and 4 kN act at A in the direction of AD, AC and AB respectively. Determine the resultant R in magnitude and direction. Also determine the magnitude and direction of the forces along AJ and AH, where J and H are the midpoints of CD and BC respectively, which together will balance R.

Or

- (b) A particle P (0,0,0) acting upon by a system of space forces is as described below. Determine the magnitude and direction of the resultant force of the system.

Force	Magnitude (N)	Coordinates of a point through which the lines of action of force from P are directed
$F_1$	1000	A (3, 4, 9)
$F_2$	2000	B (5, -2, 6)
$F_3$	3000	C (-1, 3, -4)

12. (a) Find the reactions for the frame shown in figure Q12 (a). The line of action of 40 kN passes through the point A.

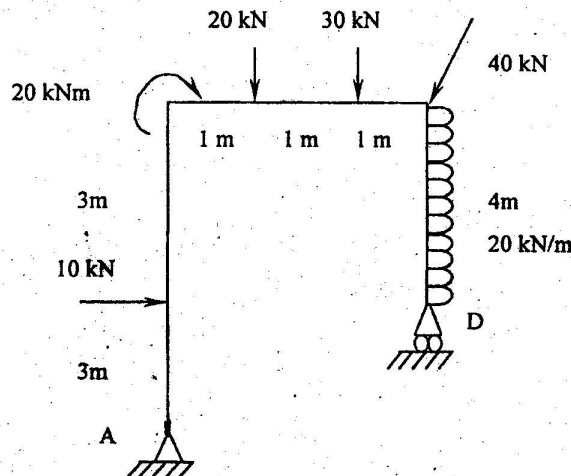

Figure Q 12 (a)

Or

- (b) Find the magnitude, direction and line of action of the resultant force with respect to A, for the system shown in figure Q 12 (b)  $AB = CD = 3$  m and  $BC = AD = 3$  m.

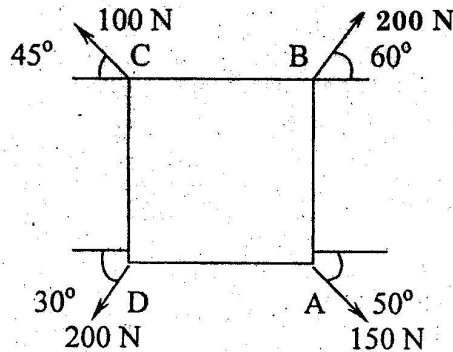

Figure Q 12 (b)

13. (a) Find the moment of inertia about both the horizontal axes for the figure shown in figure Q13(a). All dimensions are in mm.

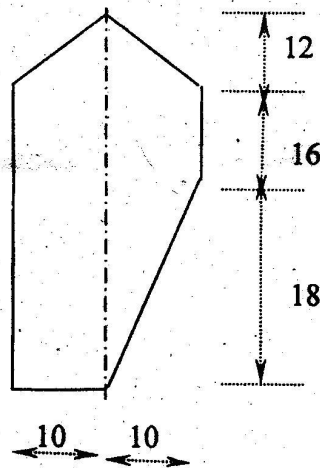

Figure Q13(a)

Or

- (b) Derive the following from the first principles (i) mass moment of inertia of a right circular cone of radius  $R$ , mass  $M$ , height  $H$  about its axis and (ii) mass moment of inertia of a circular plate of thickness  $t$  and radius  $R$  about its horizontal axis. Take the mass density as  $\rho$ .
14. (a) A bullet is fired from the top of a mountain of 300 m height with an initial velocity of 200 m/s at an angle of elevation of  $60^\circ$  to the horizontal. Neglecting the resistance of air, find (i) the horizontal distance from the gun to the point where the bullet strikes the ground and (ii) the greatest elevation above the ground reached by the projectile and (iii) the velocity with which it hits the ground.

Or

- (b) A mass 10 kg traveling towards right with a speed of 25 m/s collides with another mass 20 kg traveling in the same direction with a speed of 9 m/s. If the coefficient of restitution is 0.6, find the velocities of the masses after collision and loss in kinetic energy. What is the impulse on either mass?
15. (a) Two blocks on inclined planes are connected by inextensible string passing over a frictionless pulley as shown in figure Q 15 (a). The left side block weighs 100 N and the right side block weighs  $W$ . The coefficient of friction between the blocks and the inclined planes and the inclination of the planes are as shown. Find the minimum and maximum values of  $W$  so that the system is in equilibrium.

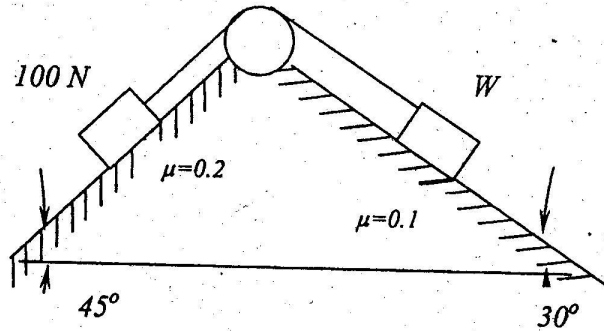

Figure Q 15 (a)

Or

- (b) A cylinder of radius 1 m rolls without slipping along a horizontal plane AB. Its centre has uniform velocity of 20 m/s. Find the velocity of points E and F on the circumference of the cylinder shown in figure Q 15 (b).

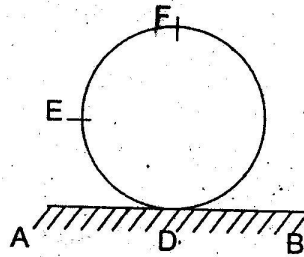

Figure Q 15 (b)