



Reg. No. :

--	--	--	--	--	--	--	--	--	--	--	--	--	--	--

Question Paper Code : 91662

B.E./B.Tech. DEGREE EXAMINATIONS, NOVEMBER/DECEMBER 2019
Second Semester
Mechanical Engineering
GE 6252 – BASIC ELECTRICAL AND ELECTRONICS ENGINEERING
(Common to all Branches)

(Regulations 2013)

(Also Common to PTGE 6252 – Basic Electrical and Electronics Engineering for
B.E. (Part-Time) – First Semester – Mechanical Engineering – Regulations – 2014)

Time : Three Hours

Maximum : 100 Marks

Answer ALL questions.

PART – A

(10×2=20 Marks)

1. State Ohm's law and its limitations.
2. Mention the errors in moving iron instruments.
3. Give some applications of DC motor.
4. Why a single phase induction motors are not self starting ?
5. Draw the circuit diagram of half wave rectifier
6. List various hybrid parameters of transistor.
7. State De Morgan's theorems.
8. Convert $(777)_8$ to decimal
9. Compare analog and digital signals.
10. Mention few applications of fiber optic communication systems.

PART – B

(5×16=80 Marks)

11. a) Calculate (i) equivalent resistance across the terminal of the supply (ii) total current supplied by the source (iii) power delivered to 16Ω resistor the circuit shown below.

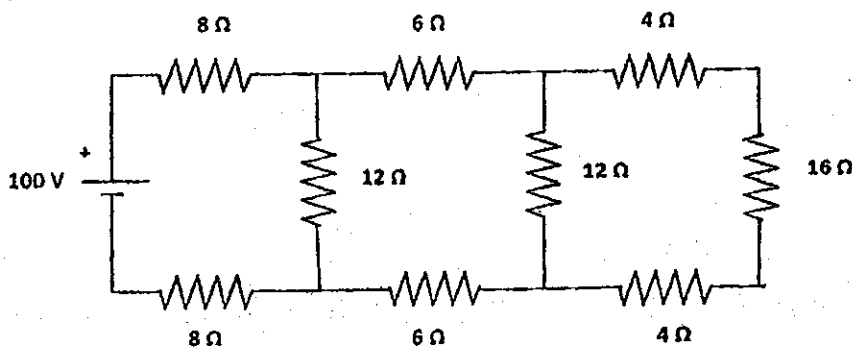

(OR)



- b) Draw and explain the working principle of attraction type, repulsion type M.I. instruments and derive its deflecting torque. (8)
12. a) i) Describe various types self excited of DC generators with their circuit layout. (8)
 ii) Explain the characteristics of DC shunt motor. (8)
- (OR)
- b) Explain the tests on single phase transformer and develop an equivalent circuit from the tests. (16)
13. a) Describe the working of a PN junction diode with neat diagrams. Also explain its V-I characteristics. (16)
- (OR)
- b) i) Let $V_{BB} = 10V$, $R_B = 1M$, $\beta = 100$, $V_{CC} = 15$, $R_L = 10\Omega$ in the transistor circuit, find (1) I_B (2) I_C (3) I_E , (4) V_{CE} Neglect V_{BE} . (8)
 ii) Explain the working of zener diode and its applications. (8)
14. a) i) Prove the Boolean identify
 $AB + A\bar{B} + \bar{A}B = A + B$. (4)
 ii) Explain the working of JK and D flip flops (12)
- (OR)
- b) With a neat diagram explain in the working of 4 bit binary ripple counter. (16)
15. a) Describe the principle of Amplitude and Frequency Modulation. (8+8)
- (OR)
- b) i) Draw the block diagram and explain the working of Satellite Communication Systems. (12)
 ii) Mention its merits and demerits. (4)