

Reg. No. :

--	--	--	--	--	--	--	--	--	--	--	--	--	--	--	--	--	--	--	--

Question Paper Code : 31465

B.E./B.Tech. DEGREE EXAMINATION, JANUARY 2014.

First Semester

Civil Engineering

GE 2111/ME 51 — ENGINEERING GRAPHICS

(Common to all branches)

(Regulation 2008)

Time : Three hours

Maximum : 100 marks

Answer ALL questions.

(5 × 20 = 100)

1. (a) Draw the involute of a circle of diameter 30 mm. Draw the tangent and normal at any point "P" and name them.

Or

- (b) Draw by free hand the top view, front view and right side view of the object shown in fig.1.

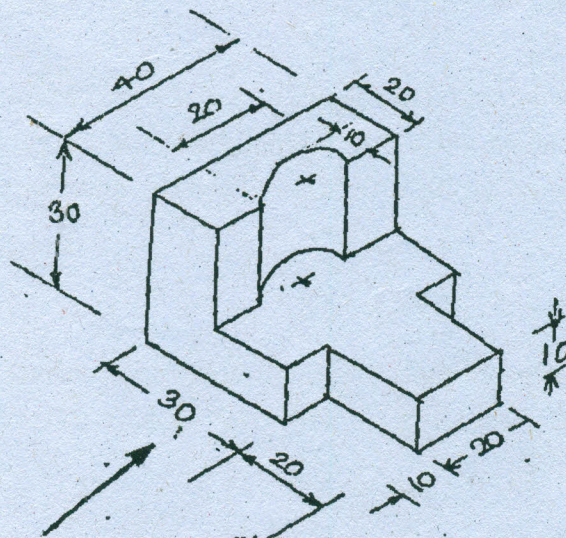

Figure 1

(All dimensions are in mm)

2. (a) (i) A magician performs the trick of a floating stick. As seen by a person sitting right in front, as per the orthographic projection rules, the stick has its ends 0.2 m and 0.6 m above the floor and appears to be inclined at 30° to the floor. The same two ends are found to be 0.1 m and 0.7 m respectively in front of the screen, arranged behind the stick. Adopting a suitable scale, draw the projections of the stick. Also, find the true length of the stick and its true angles of inclination with the floor and the vertical screen. (10)
- (ii) A rhombus of diagonals 25 mm and 15 mm with longer diagonal being parallel to xy-line represents the top view of a square of diagonal 25 mm, with a corner on HP. Draw its front view. (10)

Or

- (b) (i) A straight line AB of length 100mm has its end A 10 mm in front of VP and B 20 mm above HP. The front view and top view of the line measure 80 mm and 60 mm respectively. Draw the projections of the line and obtain the true angles of inclination with HP and VP. (10)
- (ii) A hexagonal lamina of side 30 mm is resting on HP on one of its corners with the sides containing the corner being equally inclined to HP. The surface of the lamina makes an angle of 30° with HP. Draw the top view and front view of the lamina if the plan of the diagonal passing through that corner is inclined at 50° to xy-line. (10)
3. (a) A square prism of base side 30 mm and axis 70 mm rests on HP on one of its longer edges with the rectangular faces equally inclined to HP. The axis is inclined at 30° to VP. Draw the top and front views of the prism.

Or

- (b) Draw the projections of a right circular cone of base diameter 60 mm and altitude 80 mm lying on HP with one of its generators. The axis is parallel to VP.

4. (a) A cylinder of diameter 50 mm and height 60 mm rests on its base on HP. It is cut by a plane perpendicular to VP and inclined at 45° to HP. The cutting plane meets axis at a distance of 15mm from the top. Draw the sectional plan, elevation and the true shape of the section.

Or

- (b) A lamp shade is formed by cutting a cone of base diameter 144 mm and height 174 mm by a horizontal plane at a distance of 72 mm from the apex and another plane inclined at 30° to HP, passing through one of the extremities of the base. Draw the development of the shade. Adopt a suitable scale.
5. (a) A sphere of radius 50 mm is kept centrally over a frustum of square pyramid of side 120 mm at the bottom and 80 mm at the top and height 100 mm. Draw the isometric view of the assembly.

Or

- (b) A square pyramid of base edge 20 mm and altitude 40 mm rests on its base on the ground with a base edge parallel to the picture plane. The axis of the pyramid is 25 mm behind the PP and 25 mm to the right of the eye. The eye is 50 mm in front of the PP and 50 mm above the ground. Draw the perspective view of the pyramid.
-