

Reg. No. :

--	--	--	--	--	--	--	--	--	--	--	--	--	--	--	--	--	--	--	--

Question Paper Code : 51007

B.E./B.Tech. DEGREE EXAMINATIONS, JANUARY 2012.

First Semester

GE 2111 — ENGINEERING GRAPHICS

(Common to all branches)

(Regulations 2008)

Time : Three hours

Maximum : 100 marks

Answer ALL questions.

(5 × 20 = 100 marks)

1. (a) Draw the involute of a circle of diameter 50 mm when a string is unwound in the clockwise direction. Draw a tangent and normal at a point located on the involute. (20)

Or

- (b) Make free hand sketches of the front, top and right side views of the object shown below in Fig. 1 (b). (20)

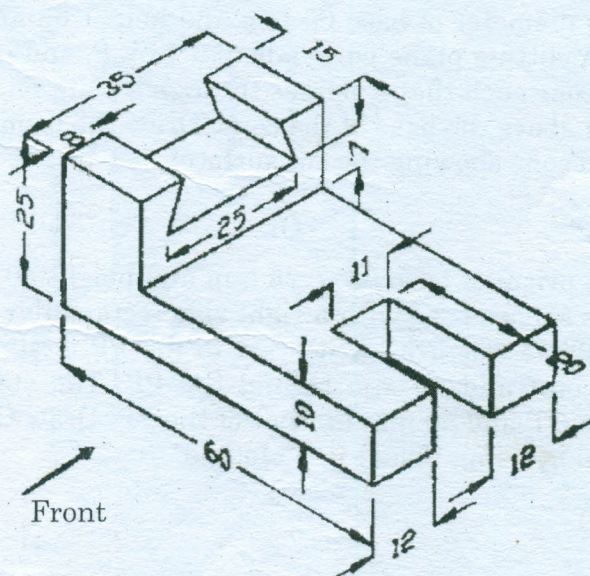

Fig. 1 (b)

2. (a) The front view of a line AB 90 mm long is inclined at 45° to XY line. The front view measures 65 mm long. Point A is located 15 mm above H.P. and is in V.P. Draw the projections and find its true inclinations. (20)

Or

- (b) A hexagonal lamina of side 30 mm rests on one of its edges on H.P. This edge is parallel to V.P. The surface of the lamina is inclined 60° to H.P. Draw its projections. (20)
3. (a) A hexagonal prism of side of base 25 mm and axis 60 mm long, is freely suspended from a corner of the base. Draw the projections by the change of Position method. (20)

Or

- (b) A cylinder, diameter of base 60 mm and height 70 mm, is having a point of its periphery of base on H.P. with axis of the cylinder inclined to H.P. at 45° and parallel to V.P. Draw the projections of the cylinder. (20)
4. (a) A cone of base 75 mm diameter and axis 80 mm long is resting on its base on the H.P. It is cut by a section plane perpendicular to the V.P. and parallel to and 12 mm away from one of its end generators. Draw its front view, sectional top view and true shape of the section. (20)

Or

- (b) A regular hexagonal pyramid side of base 30 mm and height 60 mm is resting vertically on its base on H.P. such that two of its sides of the base are perpendicular to V.P. It is cut by a plane inclined at 40° to H.P. and perpendicular to V.P. The cutting plane bisects the axis of the pyramid. Obtain the development of the lateral surface of the truncated pyramid. (20)
5. (a) A cone of diameter of base 60 mm and height 65 mm rests with its base on H.P. A cutting plane perpendicular to V.P. and inclined at 30° to H.P. cuts the cone such that it passes through a point on the axis at a distance of 30 mm above the base of the cone. Draw the isometric projection of the truncated cone showing the cut surface. (20)

Or

- (b) A square prism of base 25×25 mm and height 40 mm is resting on the GP on its square base with a right side rectangular face making 60° with Picture Plane. The corner nearest to the PP is 40 mm to the left of the station point and 20 mm behind the PP. The station point is 60 mm above the GP and 50 mm in front of the PP. Draw the perspective view of the prism by using Visual Ray Method. (20)