

Reg. No. :

--	--	--	--	--	--	--	--	--	--	--	--	--	--	--	--	--	--	--	--

Question Paper Code : 80504

B.E./B.Tech. DEGREE EXAMINATION, NOVEMBER/DECEMBER 2016.

First Semester

Civil Engineering

GE 6152 — ENGINEERING GRAPHICS

(Common to all branches)

(Regulations 2013)

Time : Three hours

Maximum : 100 marks

Answer ALL questions.

(5 × 20 = 100)

1. (a) An inelastic string of 150 mm long has its one end attached to the circumference of a circular disc of 40 mm diameter. Draw the curve traced out by the other end of the string when it is completely wound around the disc keeping the string always tight Name the curve obtained. Draw the tangent and normal to the curve at a point distant 100 mm from the centre of the disc.

Or

- (b) Draw the elevation, plan and left side view of the solid shown below.

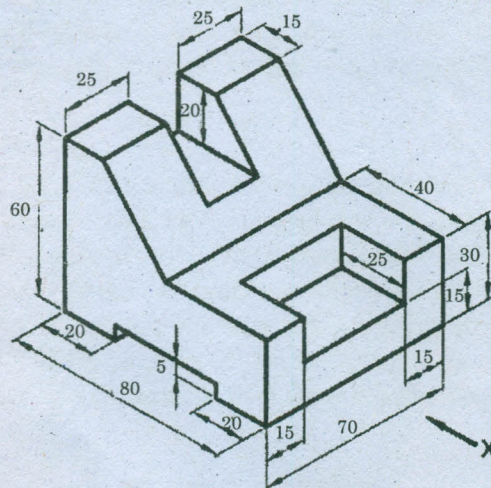

(All dimensions are in mm)

2. (a) A room is $4.8 \text{ m} \times 4.2 \text{ m} \times 3.6 \text{ m}$ high. Determine graphically, the distance between a top corner and the bottom corner diagonally opposite to it.

Or

- (b) An equilateral triangle ABC of side 70 mm is so placed that the side AB is parallel to HP and inclined at 40° to VP . The difference in height between C and A is 30 mm . Draw the projections of the triangle.

3. (a) A square prism of 40 mm and base side 60 mm long axis is kept on the VP on a corner of its base such that the longer edge containing that corner (on the HP) makes an angle of 30° to the VP . Draw the projection.

Or

- (b) A cylindrical disc of 60 mm diameter and 20 mm thickness has a central coaxial square hole with 40 mm long diagonals. Draw the projections of the disc when the flat faces of the disc are vertical and inclined at 45° to the VP and the faces of the hole are equally inclined to the HP .

4. (a) Draw the development of lateral surface of a hexagonal pyramid with a 40 mm base side and a 60 mm long axis, which is resting on its base in the HP . such that an edge of the base is perpendicular to VP , when an auxiliary inclined plane whose $V.T.$ makes an angle 60° with HP , bisects the axis.

Or

- (b) A cone, having a 60 mm base diameter and a 70 mm long axis, is resting on its base on the ground. It is cut by a plane such that the true shape of the section is a rectangular hyperbola with a 40 mm base and seen in the front view. Draw the sectional front view and find the distance of the section plane from the axis of the cone.

5. (a) A square pyramid rests centrally over a cylindrical block. Draw the isometric projection of the arrangement. Consider the pyramid has a base with 25 mm side and 40 mm long axis whereas the cylindrical block has a base with 50 mm diameter and 20 mm thickness.

Or

- (b) A cube of 25 mm side is placed vertically with one of its edges on the picture plane and the top square end face touching an auxiliary ground plane at a height of 45 mm above the horizon plane. The vertical edge formed by the two adjacent rectangular faces which are inclined at 45° to the picture plane, touches the picture plane. Draw the perspective view of the cube if the station point is 70 mm in front of the picture plane and lies in the central plane which is 30 mm to the right side of the centre of the cube.