

10-5-17  
AN

Reg. No. :

--	--	--	--	--	--	--	--	--	--	--	--	--	--	--	--	--	--	--	--

**Question Paper Code : 71940**

B.E./B.Tech. DEGREE EXAMINATION, APRIL/MAY 2017.

First Semester

Mechanical Engineering

GE 6152 — ENGINEERING GRAPHICS

(Common to Mechanical Engineering (Sandwich), Aeronautical Engineering, Agriculture Engineering, Automobile Engineering, Biomedical Engineering, Civil Engineering, Computer Science and Engineering, Electrical and Electronics Engineering, Electronics and Communication Engineering, Electronics and Instrumentation Engineering, Environmental Engineering, Geoinformatics Engineering, Industrial Engineering, Industrial Engineering and Management, Instrumentation and Control Engineering, Manufacturing Engineering, Marine Engineering, Materials Science and Engineering, Mechanical and Automation Engineering, Mechatronics Engineering, Medical Electronics Engineering, Metallurgical Engineering, Petrochemical Engineering, Production Engineering, Robotics and Automation Engineering, Biotechnology, Chemical Engineering, Chemical and Electrochemical Engineering, Fashion Technology, Food Technology, Handloom and Textile Technology, Industrial Bio Technology, Information Technology, Leather Technology, Petrochemical Technology, Petroleum Engineering, Pharmaceutical Technology, Plastic Technology, Polymer Technology, Rubber and Plastics Technology, Textile Chemistry, Textile Technology, Textile Technology (Fashion Technology), Textile Technology (Textile Chemistry))

(Regulations 2013)

Time : Three hours

Maximum : 100 marks

Answer ALL questions.

(5 × 20 = 100)

1. (a) (i) The distance between two stations is 100 km and on a road map it is shown by 30 cm. Draw a diagonal scale and indicate 46.8 km on it. (10)
- (ii) Construct a hyperbola with the distance between the focus and directrix as 50 mm and eccentricity as  $\frac{3}{2}$ . Also draw the tangent and normal to the curve at a point, 25 mm from the axis. (10)

Or

- (b) Draw the front view, top view and left side view of the object shown in figure. (20)

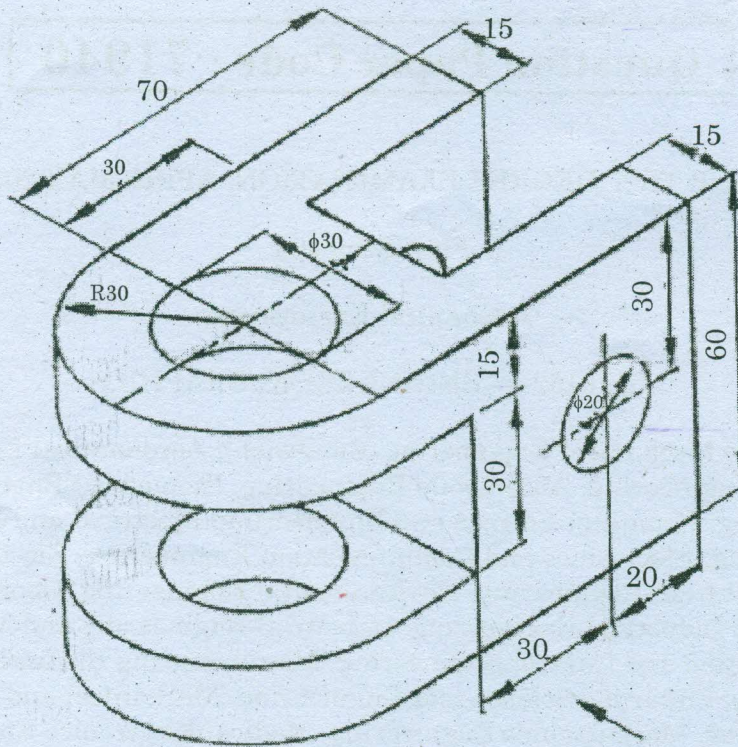

All Dimensions are in mm

2. (a) The top view of a 80 mm long line AB measures 65 mm, while the length of its front view is 55 mm. Its one end A in the H.P. and 12 mm in front of the V.P. Draw the projections of AB and determine its inclinations with the H.P. and V.P. (20)

Or

- (b) A pentagonal lamina of 30 mm side rests on the H.P. on one of its corners with its surface inclined at  $30^\circ$  to the H.P. Draw its projections when the side opposite to the resting corner is  $45^\circ$  inclined to V.P. (20)
3. (a) A hexagonal pyramid with 30 mm base side and 70 mm long axis is lying on a slant edge on the ground such that the axis is parallel to the V.P. Draw its projections. (20)

Or

- (b) A hexagonal prism of 30 mm base side and axis 65 mm long, has an edge of its base in the V.P. such that the axis is inclined at  $30^\circ$  to the V.P. and parallel to the H.P. Draw its projections. (20)

4. (a) A square pyramid of 40 mm base side and 65 mm long axis has its base on the H.P. and all the edges of base are equally inclined to the V.P. It is cut by a section plane perpendicular to the V.P. and inclined at  $45^\circ$  to the H.P. and bisecting the axis. Draw the sectional top view and true shape of the section. (20)

Or

- (b) A cone with a 50 mm base diameter and 60 mm long axis, rests with its base on the H.P. Draw the development of its lateral surface when it is cut by an auxiliary inclined plane which bisecting the axis and inclined  $60^\circ$  to the H.P. (20)
5. (a) A sphere of radius 50 mm is kept centrally over a frustum of square pyramid of side 120 mm at the bottom and 80 mm at the top and height 100 mm. Draw the isometric view of the assembly. (20)

Or

- (b) A square prism of base side 40 mm and height 70 mm rests with its base on the ground such that one of its rectangular faces is parallel and 10 mm behind picture plane. The station point is 30 mm in front of picture plane, 80 mm above the ground plane and lies in a central plane 40 mm to the right of the corner of the prism. Draw the perspective projection of the prism. (20)