

PART C — (1 × 15 = 15 marks)

16. (a) 2500 pieces of hollow hexagonal headed mild steel bolts as shown in Fig. 2 are to be produced by machining. Select a suitable lathe and blank for machining. Identify and list the various elementary machining operations involved. Prepare an operation chart indicating tools, tool positions and the machining conditions. Also, draw a tool layout for machining the given job in an appropriate lathe machine.

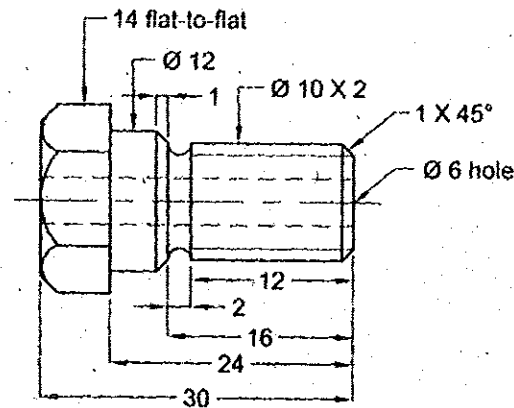

Fig. 2 Hollow hexagonal headed mild steel bolt

Or

- (b) A blank 180 mm long and 7 mm diameter is to be machined in a lathe to 175 mm long and 60 mm diameter. The workpiece rotates at 450 rpm, the feed rate is 0.3 mm/rev; and the maximum depth of cut is 2 mm. For turning operation, the approach plus over distance is 6 mm. Assuming that the facing operation is done after the turning, calculate the machining time.

Reg. No. :

**Question Paper Code : 53304**

B.E./B.Tech. DEGREE EXAMINATIONS, APRIL/MAY 2019.

Fourth/Sixth Semester

Mechanical Engineering

ME 6402 – MANUFACTURING TECHNOLOGY — II

(Common to Mechanical Engineering (Sandwich)/Industrial Engineering/Industrial Engineering and Management/Mechanical and Automation Engineering)

(Regulation 2013)

(Also common to PTME 6402 – Manufacturing Technology – II for B.E. (Part-Time) – Third Semester – Mechanical Engineering – Regulation 2014)

Time : Three hours

Maximum : 100 marks

Answer ALL questions.

PART A — (10 × 2 = 20 marks)

1. Define tool life and list the factors affecting tool life.
2. What are the functions of cutting fluids?
3. How does a turret lathe differ from an engine lathe?
4. What is meant by the designation 12 × 36 inch lathe?
5. Write the difference between up milling and down milling.
6. What can a mill-turn center do that a conventional turning center cannot do?
7. What is dressing, in reference to grinding wheels?
8. Compare push broaching and pull broaching.
9. List the three basic components of a numerical control system.
10. What is manual data input in NC part programming?

PART B — (5 × 13 = 65 marks)

11. (a) (i) With neat sketches briefly describe the different types of chips that occur in metal cutting. (8)
- (ii) State the conditions under which use of positive and negative rake angles are recommended. (5)

Or

- (b) (i) Explain the different types of tool wear that occur in metal cutting. (8)
- (ii) Explain briefly the effect of cutting speed, feed and depth of cut on the surface finish obtainable. (5)
12. (a) (i) Discuss the characteristics and applications of Swiss type single spindle automatic lathe with neat sketch. (5)
- (ii) Describe the different types of operations that can be performed on a lathe. (8)

Or

- (b) (i) Explain the construction of centre lathe with neat sketch. (5)
- (ii) Discuss the different types of attachments that can be used in a lathe. (8)
13. (a) (i) Discuss the following operations with neat sketches :
- (1) Drilling
  - (2) Reaming
  - (3) Boring and
  - (4) Tapping. (8)
- (ii) With a simple sketch, explain the working of the crank and slotted link quick return motion mechanism used in shaper. (5)

Or

- (b) (i) Explain gear hobbing process with neat sketch. (5)
- (ii) With a neat sketch explain the column and knee type milling machine and name its main parts? (8)

14. (a) (i) List the factors to be considered while selection of grinding wheel. (5)
- (ii) Discuss the following :
- (1) Glazing of grinding wheel and
  - (2) Dressing of grinding wheel. (8)

Or

- (b) (i) Explain the working of centreless grinding machine with neat sketch and state its advantages and disadvantages. (8)
- (ii) Discuss grit, grade and structure in grinding wheels. (5)
15. (a) (i) Discuss point to point, straight line/cut and continuous NC system with appropriate examples. (8)
- (ii) Discuss the requirements of a good slide way system. (5)

Or

- (b) Write an efficient CNC part program to drill 35 holes of diameter of 0.5 inch each in a machine component as shown in the figure. 1. The raw material to be employed is mild steel plate of 0.4 inch thickness. (13)

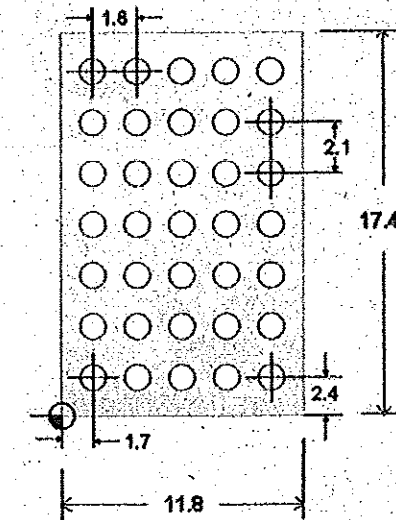

Mild Steel Plate (All dimensions are in inches)

Fig. 1 A component to be machined (drilled)