

Reg. No. :

--	--	--	--	--	--	--	--	--	--	--	--	--	--	--	--	--	--	--	--

Question Paper Code : 31040

B.E./B.Tech. DEGREE EXAMINATION, MAY/JUNE 2013.

Fifth Semester

Mechanical Engineering

080120025 — DESIGN OF MACHINE ELEMENTS

(Common to Automobile Engineering)

(Regulation 2008)

Time.: Three hours

Maximum : 100 marks

Note: Approved Design Data Book is permitted to use in the Examination)

(Use of PSG design data book is permitted)

Assumptions and Assumed data have to be stated clearly.

Answer ALL questions.

PART A — (10 × 2 = 20 marks)

1. What are the factors to be considered for deciding the magnitude of factor of safety?
2. List out the methods of reducing stress concentration factor.
3. State Castiglione's theorem.
4. What is the difference between rigid and flexible coupling?
5. Why are through bolts not preferred in assembly applications?
6. Which factor causing residual stress in welded joint? How are they relieved?
7. Define spring index.
8. What is Wahl factor and why is it required?
9. Differentiate sliding contact and rolling contact bearings.
10. In what respect the flywheel differs from the governor.

PART B — (5 × 16 = 80 marks)

11. (a) A hollow shaft is required to transmit 600kW at 110 r.p.m., the maximum torque being 20% greater than the mean. The shear stress is not to exceed 63 MPa and twist in a length of 3 meters not to exceed 1.4 degrees. Find the external diameter of the shaft, if the internal diameter to the external diameter is 3/8. Take modulus of rigidity as 84 GPa.

Or

- (b) A machine component is subjected to fluctuating stress that varies from 40 to 100 N/mm². The corrected endurance limit stress for the machine component is 270 N/mm². The ultimate tensile strength and yield strength of material are 600 and 450 N/m² respectively. Find the factor of safety using: (i) Gerber theory; (ii) Soderberg line; (iii) Goodman line; and (iv) Also, find factor of safety against static failure.
12. (a) The layout of a shaft carrying two pulleys 1 and 2, and supported on two bearings A and B is shown in figure. The shaft transmits 7.5 kW power at 360 rpm from pulley 1 to pulley 2. The diameters of pulley 1 and 2 are 250 and 500 mm respectively. The masses of pulley 1 and 2 are 10 and 30 kg respectively. The belt tensions act vertically downward and the ratio of belt tensions on the tight side to slack side for each pulley are 2.5:1. The shaft is made of plain carbon steel 40 C8 ($S_{yt} = 380 \text{ N/mm}^2$) and the factor of safety is 3. Estimate suitable diameter of shaft. If the permissible angle of twist is 0.5° per meter length, calculate the shaft diameter on the basis of torsional rigidity. Assume $G = 79300 \text{ N/mm}^2$.

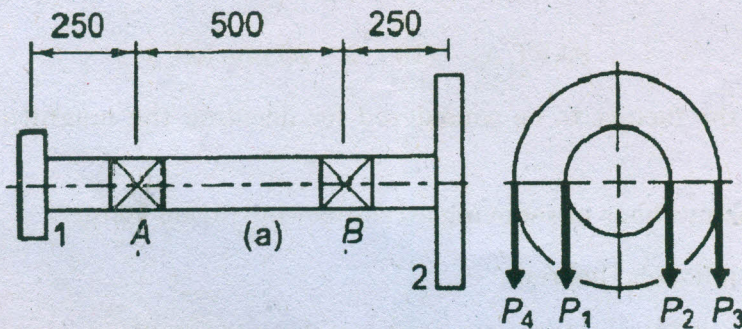

Note: All dimensions are in 'mm'.

Or

- (b) It is required to design a bushed — pin type flexible coupling to connect the output shaft of an electric motor to the shaft of a centrifugal pump. The motor delivers 20 kW power at 720 rpm. The starting torque of motor can be assumed to be 150% of the rated torque. Design the coupling and specify the dimensions of its components.

13. (a) A cast iron bracket as shown in figure supports a load of 10 kN. It is fixed to the horizontal channel by means of four identical bolts, two at A and two at B. The bolts are made of steel 30 C8 ($S_{yt} = 400 \text{ N/mm}^2$) and the factor of safety is 6. Determine the major diameter of the bolts if $d_c = 0.8d$.

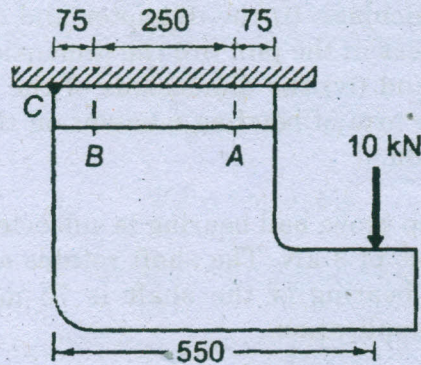

Note: All dimensions are in 'mm'.

Or

- (b) A bracket is welded to the vertical plate by means of two fillet welds as shown in figure. Determine the size of the welds, if the permissible shear stress is limited to 70 N/mm^2 .

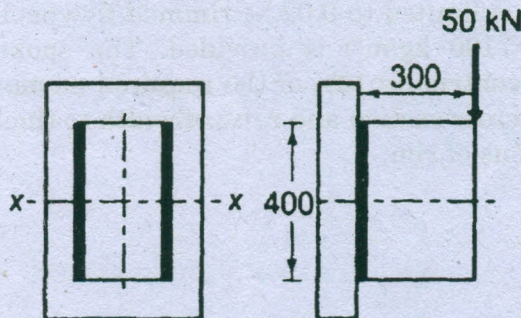

Note: All dimensions are in 'mm'.

14. (a) A safety valve, 50 mm in diameter, is to blow off at a pressure of 1.5 MPa. It is held on its seat by means of a helical compression spring, with an initial compression of 25 mm. The maximum lift of valve is 10 mm. The spring index can be taken as 6. The spring is made of patented and cold drawn steel wire with ultimate strength of 1500 N/mm^2 and modulus of rigidity of 81370 N/mm^2 . The permissible shear stress for the spring wire should be taken as 30% of the ultimate tensile strength. Design the spring and calculate:

- (i) Wire diameter; (ii) mean coil diameter; (iii) number of active turns; (iv) Total number of turns; (v) solid length of spring; (vi) free length of spring; (vii) pitch of the coil.

Or

- (b) A right angled bell crank lever is designed to raise a load of 5 kN at the short arm end. The lengths of the short and long arms are 100 and 450 mm respectively. The lever and pins are made of 30C8 ($S_{yt} = 400 \text{ N/mm}^2$) and the factor of safety is 5. The permissible bearing pressure on the pin is 10 N/mm^2 . The lever has a rectangular cross section and the ratio of width to thickness is 3:1. The length to diameter ratio of fulcrum pin is 1.25:1. Calculate: (i) the diameter and the length of fulcrum pin; (ii) the shear stress in the pin; (iii) the dimensions of the boss of the lever at the fulcrum and (iv) the dimensions of the cross section of the lever. Assume that the arm of bending moment on the lever extends up to the axis of the fulcrum.
15. (a) A single row deep groove ball bearing is subjected to a radial force of 8 kN and a thrust force of 3 kN. The shaft rotates at 1200 rpm. The expected life L_{10th} of the bearing of the shaft is 75 mm. Select a suitable ball bearing for this application.

Or

- (b) The tuning moment diagram of a multi-cylinder engine is drawn with a scale of ($1\text{mm} = 1^\circ$) on the abscissa and ($1 \text{ mm} = 250 \text{ N-m}$) on the ordinate. The intercepted areas between the torque developed by the engine and the mean resisting torque of the machine, taken in order from one end are -350, +800, +600, +900, -550, +450 and -650 mm^2 . The engine is running at a mean speed of 750 rpm and the coefficient of speed fluctuations is limited to 0.02. A rimmed flywheel made of grey cast iron FG 200($\rho = 7100 \text{ kg/m}^3$) is provided. The spokes, hub and shaft are assumed to contribute 10% of the required moment inertia. The rim has rectangular cross section and ratio of width to thickness is 1.5. Determine the dimensions of rim.