

Reg. No. :

--	--	--	--	--	--	--	--	--	--	--	--	--	--	--	--	--	--	--	--

Question Paper Code : 80663

B.E./B.Tech. DEGREE EXAMINATION, NOVEMBER/DECEMBER 2016.

Fifth Semester

Mechanical Engineering

ME 6503 — DESIGN OF MACHINE ELEMENTS

(Regulations 2013)

(Common to B.E. Automobile Engineering, Mechanical and Automation Engineering, Mechatronics Engineering and Sixth Semester Mechanical Engineering (Sandwich))

Time : Three hours

Maximum : 100 marks

Note : Use of Approved Design Data Book is permitted.

Any required design data can be suitably assumed.

Answer ALL questions.

PART A — (10 × 2 = 20 marks)

1. How the machine design may be classified?
2. What is an S-N Curve?
3. Define the term critical speed of a shaft.
4. What are the types of flexible coupling and rigid couplings?
5. What are the different applications of screwed fasteners?
6. State the two types of eccentric welded connections.
7. State any two functions of springs.
8. How does the function of flywheel differ from that of governor?
9. Classify the types of bearings.
10. Define the term Reliability of a Bearing.

PART B — (5 × 16 = 80 marks)

11. (a) A circular bar of 500 mm length is supported freely at its two ends. It is acted upon by a central concentrated cyclic load having a minimum value of 20 kN and a maximum value of 50 kN. Determine the diameter of bar by taking a factor of safety 1.5, size effect of 0.85, surface finish factor of 0.9. The material properties of bar are given by: ultimate strength of 650 MPa, yield strength of 500 MPa and endurance strength of 350 MPa.

Or

- (b) A hollow circular column of external diameter 250 mm and internal diameter 200 mm carries a projecting bracket on which a load of 20 kN rests, as shown in Fig. The centre of the load from the centre of the column is 500 mm. Find the stresses at the sides of the column. All dimensions in mm.

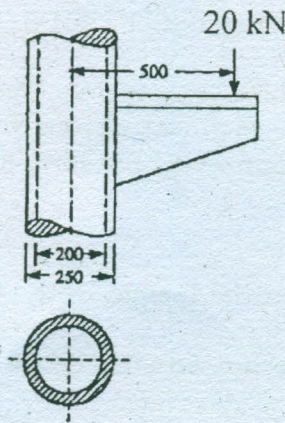

Fig. Q. 11(b)

12. (a) Design and make a neat dimensioned sketch of a muff coupling which is used to connect two steel shafts transmitting 40 kW at 350 r.p.m. The material for the shafts and key is plain carbon steel for which allowable shear and crushing stresses may be taken as 40 MPa and 80 MPa respectively. The material for the muff is cast iron for which the allowable shear stress may be assumed as 15 MPa.

Or

- (b) A hollow shaft of 0.5 m outside diameter and 0.3 m inside diameter is used to drive a propeller of a marine vessel. The shaft is mounted on bearings 6 metre apart and it transmits 5600 kW at 150 r.p.m. The maximum axial propeller thrust is 500 kN and the shaft weighs 70 kN. Determine
- The maximum shear stress developed in the shaft, and
 - The angular twist between the bearings.

13. (a) Figure shows a solid forged bracket to carry a vertical load of 13.5 kN applied through the centre of hole. The square flange is secured to the flat side of a vertical stanchion through four bolts. Estimate the tensile load on each top bolt and the maximum shearing force on each bolt. Find the bolt size, if the permissible stress is 65 MPa in shear. All dimensions in mm.

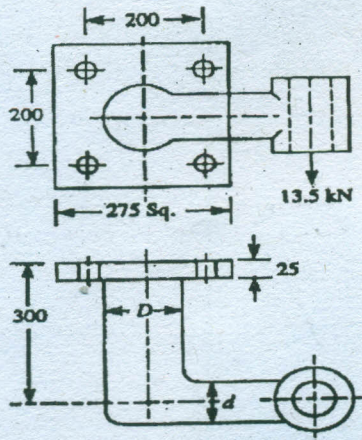

Fig. Q. 13(a)

Or

- (b) Design a double riveted butt joint with two cover plates for the longitudinal steam of a boiler shell 1.5 m in diameter subjected to a steam pressure of 0.95 N/mm². Assume joint efficiency as 75%, allowable tensile stress in the plate 90 MPa; compressive stress 140 MPa and shear stress in the rivet 56 MPa.
14. (a) The areas of the turning moment diagram for one revolution of a multi-cylinder engine with reference to the mean turning moment, below and above the line, are - 32, + 408, - 267, + 333, - 310, + 226, - 374, + 260 and -244 mm². The scale for abscissa and ordinate are: 1 mm = 2.4° and 1 mm = 650 N-m respectively. The mean speed is 300 r.p.m. with a percentage speed fluctuation of ± 1.5%. If the hoop stress in the material of the rim is not to exceed 5.6 MPa, determine the suitable diameter and cross-section for the flywheel, assuming that the Width is equal to 4 times the thickness. The density of the material may be taken to be 7200 kg/m³. Neglect the effect of the boss and arms.

Or

- (b) Design a leaf spring for the following specifications :

Total load = 140 kN; Number of springs supporting the load = 4;
 Maximum number of leaves = 10; Span of the spring = 1000 mm;
 Permissible deflection = 80 mm. Take Young's modulus, $E = 200 \text{ kN/mm}^2$
 and allowable stress in spring material as 600 MPa.

15. (a) A ball bearing subjected to a radial load of 5 kN is expected to have a life of 8000 hours at 1450 r.p.m. with a reliability of 99%. Calculate the dynamic load capacity of the bearing so that it can be selected from the manufacturer's catalogue based on a reliability of 90%.

Or

- (b) Design a journal bearing for 12 MW, 1000 rpm steam turbine, which is supported by two bearings. Take the atmospheric temperatures as 16°C and operating temperature of oil as 60°C. Assume viscosity of oil as 23 centistokes.
-