

1-6  
En

Reg. No. :

--	--	--	--	--	--	--	--	--	--	--	--	--	--	--	--	--	--	--	--

**Question Paper Code : 72159**

B.E./B.Tech. DEGREE EXAMINATION, APRIL/MAY 2017.

Sixth/Seventh Semester

Mechanical Engineering

ME 6601 — DESIGN OF TRANSMISSION SYSTEMS

(Common to Mechanical Engineering (Sandwich) Mechanical and Automation Engineering)

(Regulations 2013)

Time : Three hours

Maximum : 100 marks

(Usage of PSG Design data book is permitted)

Answer ALL questions.

PART A — (10 × 2 = 20 marks)

1. A longer belt will last more than a shorter belt, why?
2. List the advantages of wire ropes compared to chains.
3. What are the effects of increasing or decreasing the pressure angle in gear design?
4. Differentiate double helical and herringbone gears.
5. What is known as formative number of teeth on bevel gears?
6. Write the conditions of self locking of worm gears in terms of lead and pressure angles.
7. Why geometric progression is selected for arranging the speeds in gear boxes?
8. What does the ray diagram of gear box indicate?
9. Differentiate a brake and a dynamometer.
10. Double shoe brakes are preferred than single shoe brake, why?

PART B — (5 × 16 = 80 marks)

11. (a) Two shafts whose centers are 1 m apart are connected by a V — belt drive. The driving pulley is supplied with 100 kW and has an effective diameter of 300 mm. It runs at 1000 rpm, while the driven pulley runs at 375 rpm. The angle of groove on the pulleys is 40°. The permissible tension in 400 mm<sup>2</sup> cross sectional area of belt is 2.1 MPa. The density of the belt is 1100 kg/m<sup>3</sup>. Taking  $\mu = 0.28$ , estimate the number of belts required. Also calculate the length of the each belt.

Or

- (b) A truck equipped with a 9.5 kW engine uses a roller chain as the final drive to the rear axle. The driving sprocket runs at 900 rpm and the driven sprocket at 400 rpm with a centre distance of approximately 600 mm. Select the roller chain. Number of teeth on driving sprocket can be taken as 27 and the pitch value can be taken at the middle of  $P_{\max}$  and  $P_{\min}$  values.
12. (a) Design a spur gear drive required to transmit 45 kW at a pinion speed of 800 rpm. The velocity ratio is 3.5 : 1. The teeth are 20° full depth involute with 18 teeth on the pinion. Both the pinion and the gear are accurately hobbled and made of steel with a safe static stress of 180 N/mm<sup>2</sup>. Assume medium shock conditions,  $V_m = 12$  m/s and steel is hardened to 200 BHN.

Or

- (b) For intermittent duty of an elevator, two cylindrical gears made of alloy steel 40 Ni 2 Cr 1 Mo 28, and have to transmit 12.5 kW at a pinion speed of 1200 rpm. Design the gear pair for the following specifications: Gear ratio 3.5, Pressure angle 20°, involute full depth, helix angle 15°. Gears are expected to work 6 hours a day for 10 years. Minimum number of teeth on pinion can be taken as 20 and IS quality 8.
13. (a) Design a worm gear drive to transmit 20 HP from a worm at 1440 rpm to the worm wheel. Assume the bronze is sand chill cast. The speed of the wheel should be  $40 \pm 2\%$  rpm, initial sliding velocity can be assumed as 3 m/s and efficiency as 80%.

Or

- (b) Design a bevel gear drive to transmit 7.5 kW at 1440 rpm. Gear ratio 3. Pinion and gear are made of forged C45 steel. Life of gears 10,000 hrs. Assume surface hardened heat treatment and IS quality 6.

14. (a) Design a 9 speed gear box for a milling machine with speeds ranging from 56 to 900 rpm. The output speed is 720 rpm. Make a neat sketch of the gear box. Indicate the number of teeth on all the gears and their speeds Assuming the gears and shafts are made of C45, calculate module, centre distance and diameter of the spindle.

Or

- (b) Design a 12 speed gear box. The required speed range is 100 to 355 rpm. Draw the ray diagram, kinematic arrangement and find the number of teeth on each gear. Check for the interference.
15. (a) A multi disc clutch, steel on bronze is to transmit 20 kW at 1440 rpm. The clutch is to be operated in oil with the co-efficient of friction 0.08 and the average pressure 0.3 MPa. Space limitation permits only 230 mm as outside diameter of the clutch. Assuming uniform pressure, determine (i) size of the clutch, if the ratio of mean radius to face width is 3 (ii) actual axial force required, (iii) actual maximum pressure (iv) actual average pressure. The ratio of  $R_i/R_o$  can be chosen between 0.5 to 0.75, suitably and logically.

Or

- (b) A 400 mm radius brake drum contacts a single shoe as shown in fig. 15(b) and sustains 200 N-m torque at 500 rpm. For a coefficient of friction 0.25, determine (i) Normal force on the shoe (ii) Required force  $F$  to apply the brake for clockwise rotation (iii) Required force  $F$  to apply the brake for counter clockwise rotation (iv) The dimension  $c$  required to make the brake self-locking, assuming other dimensions remain same (v) Heat generated.

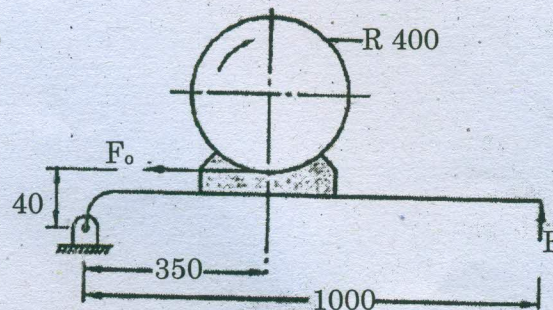

Fig. 15(b)