



Reg. No. :

--	--	--	--	--	--	--	--	--	--	--	--	--	--	--	--	--	--	--	--

Question Paper Code : 41413

B.E./B.Tech. DEGREE EXAMINATION, APRIL/MAY 2018

Sixth/Seventh Semester

Mechanical Engineering

ME 6603 – FINITE ELEMENT ANALYSIS

(Regulations 2013)

(Common to Mechanical Engineering (Sandwich)/Automobile Engineering/
Manufacturing Engineering, Mechanical and Automation Engineering)

Time : Three Hours

Maximum : 100 Marks

Answer ALL questions.

PART – A

(10×2=20 Marks)

1. Compare the Ritz technique with the nodal approximation technique.
2. Differentiate between primary and secondary variables with suitable examples.
3. What are the properties of stiffness matrix ?
4. Write the conduction, convection and thermal load matrices for 1 D heat transfer through a fin.
5. Write down the shape functions for a 4 noded quadrilateral element.
6. Distinguish between scalar and vector variable problems in 2D.
7. Write the Strain Displacement matrix for a 3 noded triangular element.
8. Distinguish between plate and shell elements.
9. What are the advantages of natural coordinates ?
10. Derive the Jacobian of transformation for a 1D quadratic element.



PART - B

(5×13=65 Marks)

11. a) A tapered bar made of steel is suspended vertically with the larger end rigidly clamped and the smaller end acted on by a pull of 10^5 N. The areas at the larger and smaller ends are 80 cm^2 and 20 cm^2 respectively. The length of the bar is 3 m. The bar weighs 0.075 N/cc . Young's modulus of the bar material is $E = 2 \times 10^7 \text{ N/cm}^2$. Obtain an approximate expression for the deformation of the rod using Ritz technique. Determine the maximum displacement at the tip of the bar.

(OR)

- b) The Governing Equation for one dimensional heat transfer through a fin of length l attached to a hot source as shown in fig. 11 b is given by

$$\frac{d}{dx} \left[-kA \frac{dT}{dx} \right] + hp(T - T_\infty) = 0$$

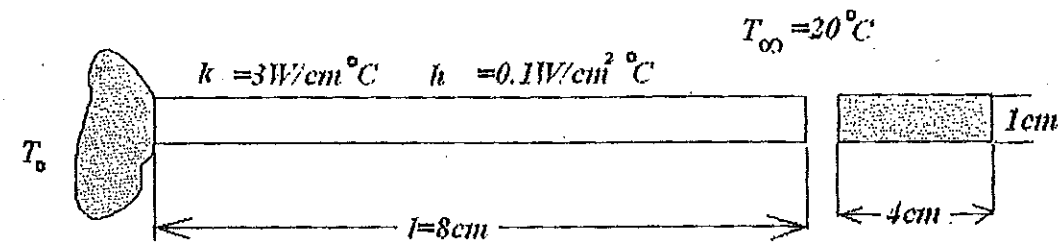

fig. 11 b

If the free end of the fin is insulated, give the boundary conditions and determine using the Collocation technique the temperature distribution in the fin. Report the temperature at the free end.

12. a) Determine the deflection in the beam, loaded as shown in Fig. 12 a, at the mid-span and at a length of 0.5 m from left support. Determine also the reactions at the fixed ends. $E = 200 \text{ GPa}$, $I_1 = 20 \times 10^{-6} \text{ m}^4$, $I_2 = 10 \times 10^{-6} \text{ m}^4$.

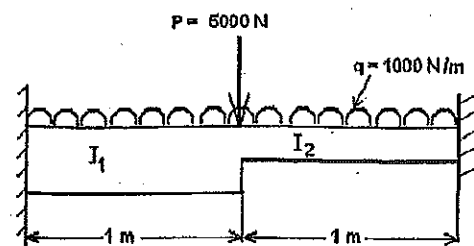

fig. 12 a

(OR)

- b) Determine the first two natural frequencies of longitudinal vibration of the stepped steel bar shown in Fig. 12 b and plot the mode shapes. All dimensions are in mm. $E = 200 \text{ GPa}$ and $\rho = 0.78 \text{ kg/cc}$. $A = 4 \text{ cm}^2$, length $l = 500 \text{ mm}$.

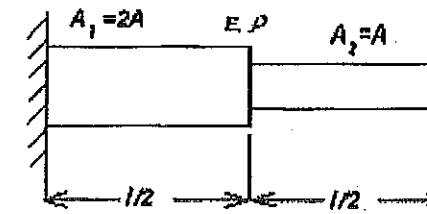

fig. 12 b

13. a) i) Determine three points on the 50°C contour line for the rectangular element shown in Fig. 13 a. The nodal values are $T_1 = 42^\circ\text{C}$, $T_2 = 54^\circ\text{C}$, $T_3 = 56^\circ\text{C}$ and $T_4 = 46^\circ\text{C}$. (8)

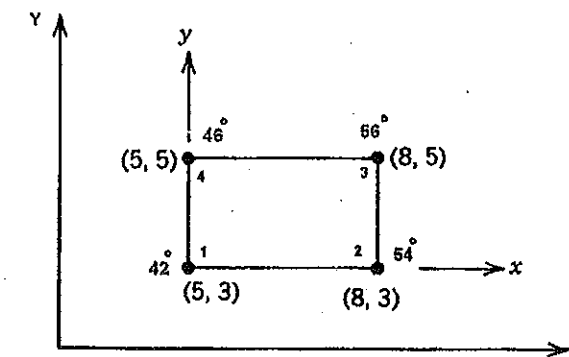

fig. 13 a

- ii) Derive the conductance matrix for a 3 noded triangular element whose nodal coordinates are known. The element is to be used for two dimensional heat transfer in a plate fin. (5)

(OR)

- b) A square shaft of cross section $1 \text{ cm} \times 1 \text{ cm}$ as shown in Fig. 13 b is to be analysed for determining the stress distribution. Considering geometric and boundary condition symmetry $1/8$ th of the cross section was modeled using four equisized triangular elements as shown. The element stiffness matrix and force vector for a triangle whose nodal coordinates are $(0, 0)$, $(0.25, 0)$ and $(0.25, 0.25)$ are given below. Carry out the assembly and determine the assembled stiffness matrix. Impose the boundary conditions and explain how the unknown stress function values at the nodes can be used to determine the shear stress.



Stiffness matrix $[K] = \frac{1}{2} \begin{bmatrix} 1 & -1 & 0 \\ -1 & 2 & -1 \\ 0 & -1 & 1 \end{bmatrix}$ Load vector $\{f\} = \begin{Bmatrix} 29.1 \\ 29.1 \\ 29.1 \end{Bmatrix}$ (13)

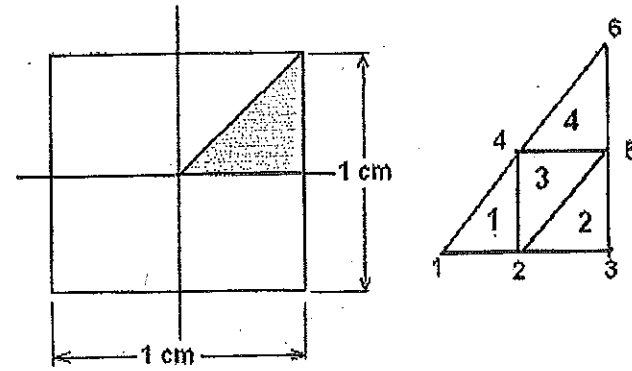

fig. 13 b

14. a) i) A thin plate of thickness 5 mm is subjected to an axial loading as shown in the Fig. 14 a. It is divided into two triangular elements by dividing it diagonally. Determine the Strain displacement matrix [B], load vector and the constitutive matrix. How will you derive the stiffness matrix? (Need not be determined). What will be the size of the assembled stiffness matrix? What are the boundary conditions? $E = 2 \times 10^7 \text{ N/cm}^2$ $\mu = 0.3$. (8)

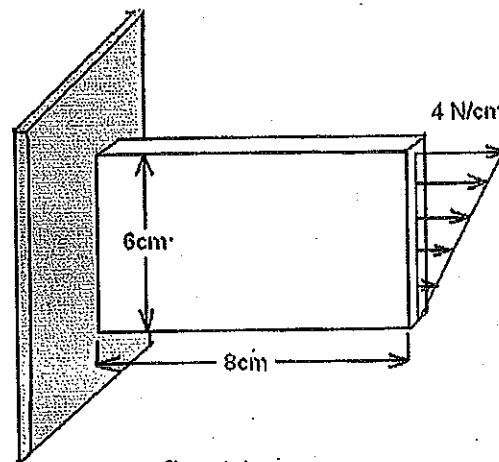

fig. 14 a

- ii) Differentiate between plane stress and plane strain analysis. (5)

(OR)



- b) i) With at least two examples explain what is meant by axisymmetric analysis. For the 3 noded triangular axisymmetric element shown in fig. 14 b derive the strain displacement matrix [B] and also the constitutive matrix [D]. (9)

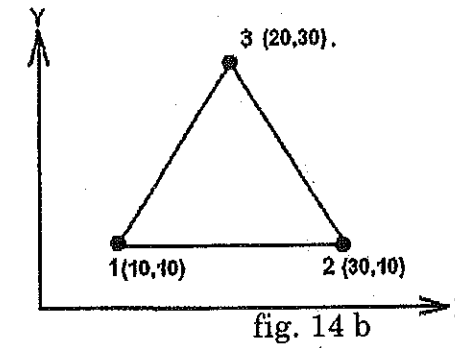

fig. 14 b

- ii) Derive the stiffness matrix for a 1D linear element. (4)

15. a) i) Using Gauss Quadrature evaluate the following integral. (7)

$$I = \int_{-1}^{+1} (4\xi^3 - 2\xi^2 + 3\xi + 6) d\xi$$

- ii) Evaluate the shape functions for one corner node and one mid side node of a nine noded quadrilateral element. (6)

(OR)

- b) i) Differentiate between subparametric, isoparametric and superparametric elements. (5)

- ii) For the four noded element shown in Fig. 15. b determine the Jacobian and evaluate its value at the point (0, 0) (8)

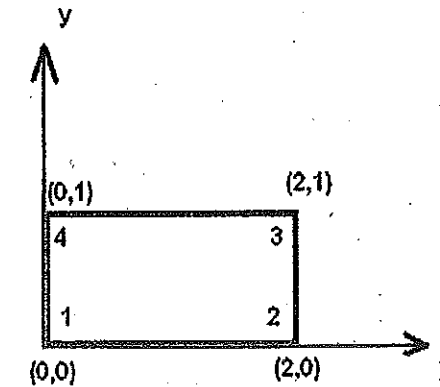

fig. 15 b

