

Reg. No.

--	--	--	--	--	--	--	--	--	--	--	--	--	--	--	--	--	--	--	--

Question Paper Code : 72109

B.E./B.Tech. DEGREE EXAMINATION, APRIL/MAY 2017.

Sixth/Seventh/Eighth Semester

Mechanical Engineering

ME 6005 — PROCESS PLANNING AND COST ESTIMATION

(Common to Manufacturing Engineering, Mechanical and Automation Engineering,
Production Engineering, Robotics and Automation Engineering)

(Regulations 2013)

Time : Three hours

Maximum : 100 marks

(Use of PSG Design Data Book is Permitted)

Answer ALL questions.

PART A — (10 × 2 = 20 marks)

1. Define process planning.
2. Write any four cutting tool materials (specify in the increasing order of hardness).
3. What is the difference between routing sheet and operations list?
4. What is the relation between tolerance and surface finish?
5. Differentiate costing from estimation.
6. What are overhead costs?
7. Define production cost.
8. What are the various material losses which can occur in a forging shop?
9. Define 'tool approach' and 'tool overtravel'.
10. Define cutting speed.

- (b) Explain the procedure followed in selecting the appropriate manufacturing process for a given product design.
12. (a) A large manufacturer requires 1200 turned components every month for a regular order. Within their tooling machine shop area there are a wide variety of machines. It is decided to investigate if there is any significant advantage of producing the components on a CNC machine as opposed to a conventional machine. The following data is available:

Conventional milling machine

Set-up time	55 min
Machining time	29 min
Material cost per unit	Rs. 200
Batch size	1200
Machinist's hourly rate	Rs. 100

CNC milling machine

Set-up time	2 h 15 min
Machining time	18 min
Material cost per unit	Rs. 200
Batch size	1200
Machinist's hourly rate	Rs. 150.

Determine:

- (i) the total component cost T for both machines;
- (ii) the break-even quantity and which machine should be used.

Or

- (b) What is inspection? Write briefly about the different methods of inspection followed in industries.
13. (a) Explain the different methods of cost estimation.

Or

- (b) Calculate the selling price per unit from the following data:

Direct material cost	= Rs. 8,000
Direct labour cost	= 60 percent of direct material cost
Direct expenses	= 5 percent of direct labour cost
Factory expenses	= 120 percent of direct labour cost
Administrative expenses	= 80 percent direct labour cost
Sales and distribution expenses	= 10 percent of direct labour cost
Profit	= 8 percent of total cost
No. of pieces produced	= 200.

14. (a) (i) Calculate the net weight and gross weight for the component shown in Fig. 14 (a). Density of material used is 7.86 gm/cc and losses = 25% of net weight. (6)

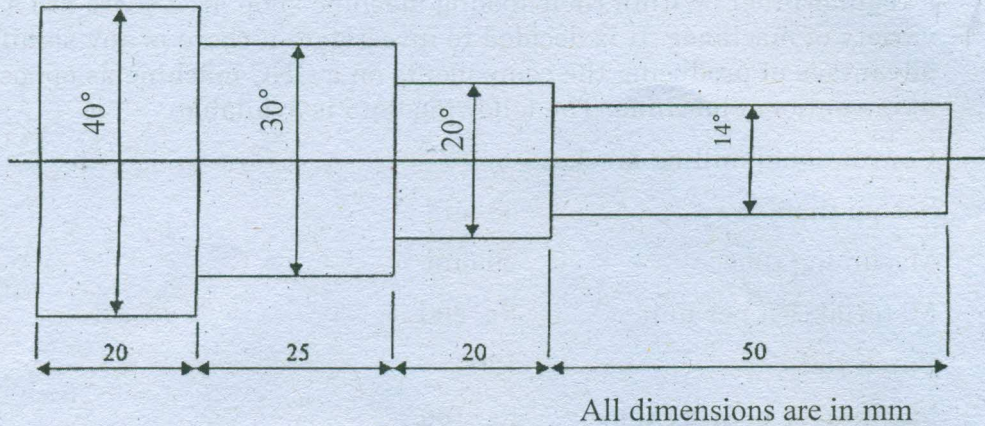

Figure 14 (a)

Also calculate

- (ii) Length of 14 mm dia bar required to forge one component. (4)

- (iii) Cost of forging/piece if:

Material cost = Rs. 80 per kg

Labour cost = Rs. 5 per piece

Overheads = 150 percent of labour cost. (6)

Or

- (b) A container open on one side of size 0.5 m \times 0.5 m \times 1 m is to be fabricated from 6 mm thick plates Fig. 14 (b). The plate metal weighs 8 gm/cc. If the joints are to be welded, make calculations for the cost of container.

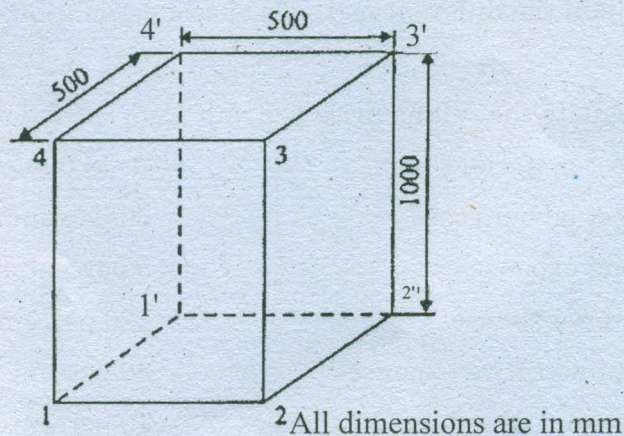

Figure 14 (b)

The relevant data is:

- Cost of plate = Rs. 10 per kg
- Sheet metal scarp (wastage) = 5 percent of material
- Cost of labour = 10 percent of sheet metal cost
- Cost of welding material = Rs. 20 per meter of weld.

15. (a) Using the data in Table and the drawing in Fig. 15(a), determine suitable speeds (rev/min) and feeds (mm/rev) and the total machining time for all operations listed. The raw material billet is $\phi 85 \times 250$ mm and the machining allowance to be used is 5 mm. The surface cutting speeds and feed rate when machining brass using HSS can be selected within the range 50–110 m/min and 0.15–8 mm/rev.

Note: Select the maximum and minimum values within the range for roughing and finishing operations respectively.

Operation description	Tooling description	Cutting condition
Face end	HSS turning tool	Finish in one pass
Turn $\phi 80 \text{ mm} \times 160 \text{ mm}$	HSS turning tool	One roughing cut, one finishing cut of 0.4 mm
Turn $\phi 70 \text{ mm} \times 100 \text{ mm}$	HSS turning tool	One roughing cut, one finishing cut of 0.4 mm
Turn $\phi 60 \text{ mm} \times 60 \text{ mm}$	HSS turning tool	One roughing cut, one finishing cut of 0.4 mm
Parting off	HSS parting off tool	Finish in one pass

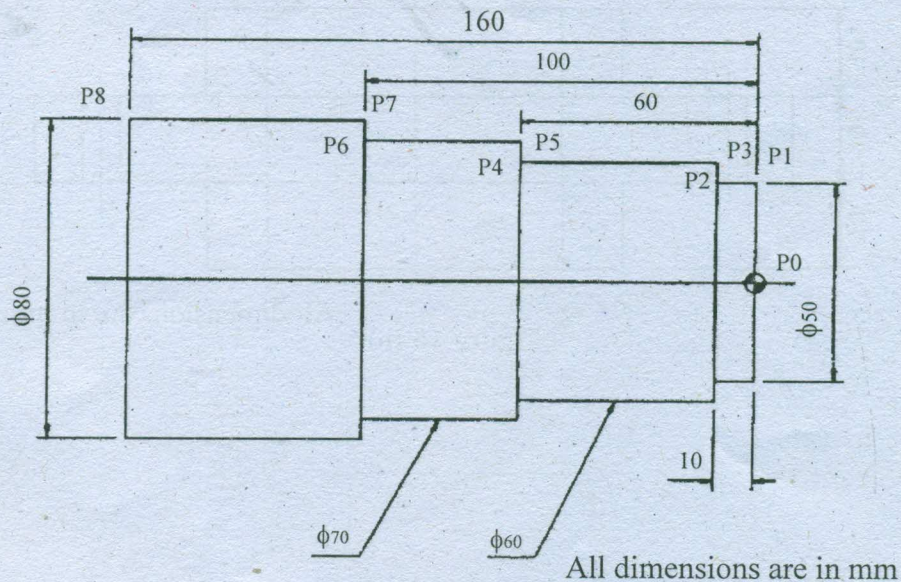

Figure 15 (a)

Or

- (b) Calculate the machining time to drill four 8 mm dia holes and one 40 mm dia central hole in the flange shown in Fig. 15 (b) 20 mm dia hole is drilled first and then enlarged to 40mm hole. Take cutting speed 10 m/min, feed for 8mm drill 0.1 mm/rev, for 20mm drill feed is 0.2 mm/rev and for 40 mm drill feed is 0.4 mm/rev.

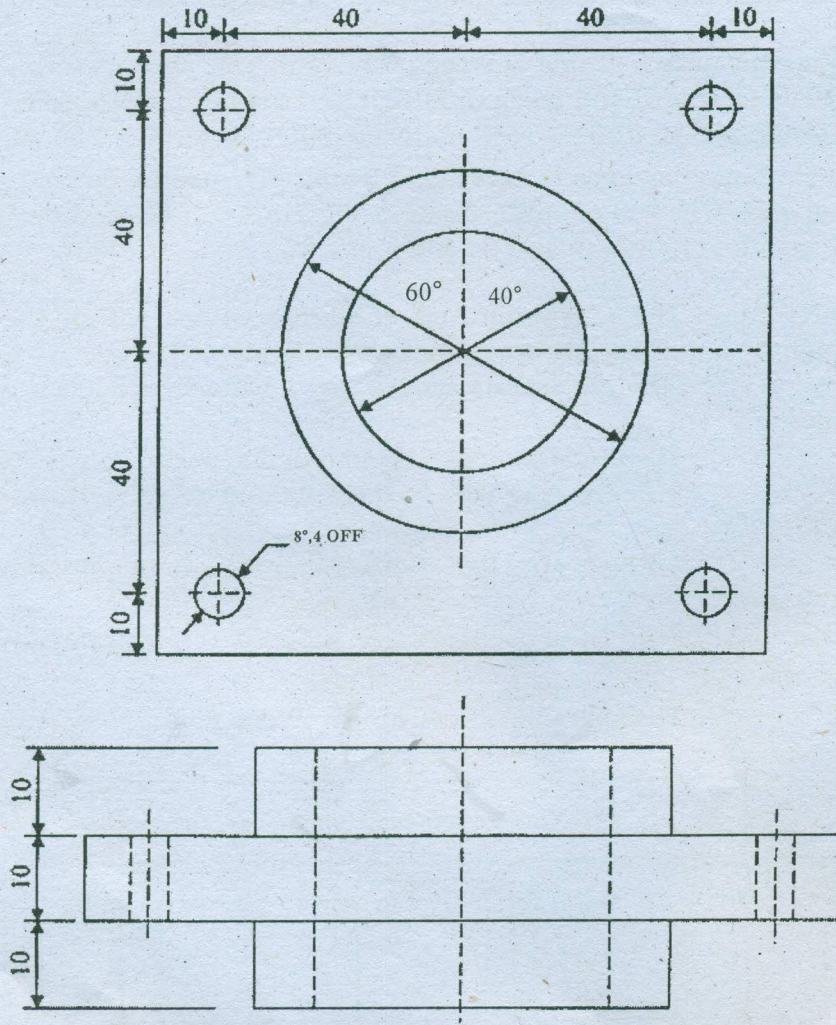

Figure 15 (b) All dimensions are in mm