

Reg. No. :

Question Paper Code : 80039

B.E./B.Tech. DEGREE EXAMINATIONS, APRIL/MAY, 2019.

Second Semester

Aeronautical Engineering

BE 8253 — BASIC ELECTRICAL, ELECTRONICS AND
INSTRUMENTATION ENGINEERING

(Common to Aerospace Engineering/Automobile Engineering/Industrial
Engineering/Industrial Engineering and Management/Manufacturing
Engineering/Marine Engineering/Material Science and Engineering/Mechanical
Engineering/Mechanical Engineering (Sandwich)/Mechanical and Automation
Engineering/Mechatronics Engineering/Production Engineering/Robotics and
Automation Engineering)

(Regulation 2017)

Time : Three hours

Maximum : 100 marks

Answer ALL questions.

PART A — (10 × 2 = 20 marks)

1. State Ohm's law and give its limitations.
2. Draw Thevenin's and Norton's equivalent circuits and give relevant equations for unknown parameters.
3. Draw the power triangle and define power factor.
4. A wire is carrying a direct current of 20 A and a sinusoidal alternating current of peak value 20 A. Find the RMS value of the resultant current in the wire.
5. State Fleming's left-hand rule.
6. Write the EMF equation of a single phase transformer.
7. Define Pinch-off voltage.
8. Design a non inverting amplifier with a gain of +5 and $R_{in} = 1 \text{ k}\Omega$ using an op-amp.
9. List any four applications of resistive transducer.
10. Classify measuring instruments based on the nature of their operations.

PART B — (5 × 13 = 65 marks)

11. (a) Derive and find the voltage across A and B of the circuit shown in Fig.11 (a).

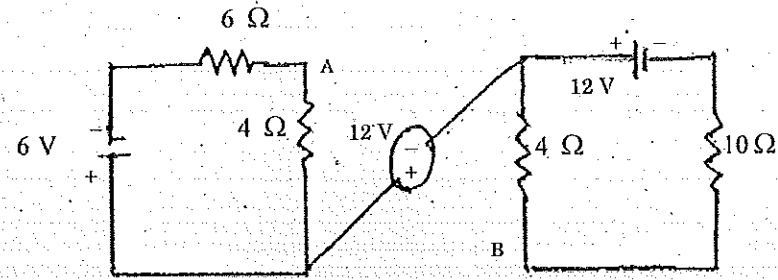

Fig.11 (a).

Or

- (b) State superposition theorem. Show with an example how superposition theorem can be usefully employed in circuit analysis.

12. (a) Explain the analysis of three phase balanced circuits using per phase equivalent circuit.

Or

- (b) Construct and explain industrial wiring diagram with an example.

13. (a) Discuss in detail, the construction and working principle of DC motor with relevant sketches.

Or

- (b) Classify and describe the working principle of different types of synchronous motor with neat diagrams.

14. (a) Explain the working and breakdown phenomenon in PN junction diode with V-I characteristics.

Or

- (b) Construct and explain 4 bit R-2R ladder Digital to Analog Converter and list its advantages.

15. (a) Describe the operating principle and applications of Hall effect sensors with appropriate diagrams.

Or

- (b) Explain three phase power measurement using two watt meter method with necessary circuit diagram, phaser diagrams and expressions.

PART C — (1 × 15 = 15 marks)

16. (a) (i) Calculate the output voltage of the circuit shown in Fig.16(a)(i). (8)

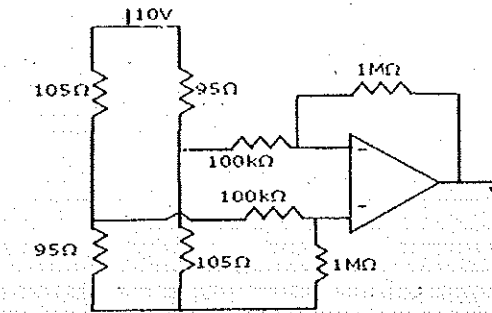

Fig.16 (a)(i).

- (ii) Identify the function of the circuit shown in Fig.16(a)(ii) by assuming the operational amplifier to be ideal. (7)

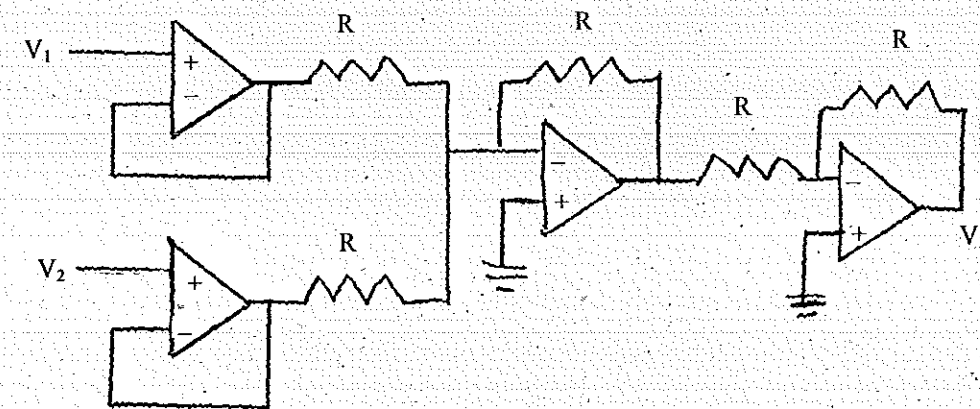

Fig.16(a)(ii)

Or

- (b) (i) A 4-pole, 250 V, 7.5 kW wave connected shunt motor has an armature resistance of 0.4Ω and a field resistance of 125Ω . Estimate approximately the current taken by the motor on no-load if the full-load efficiency of the motor is 86%. (7)
- (ii) A 20 kVA, 440V / 220V 1-phase Transformer has resistances of 0.07Ω and 0.033Ω . The values of the reactances are 0.25Ω and 0.037Ω : Calculate
- (1) the total resistance referred to the primary. (2)
 - (2) the total resistance referred to the secondary. (2)
 - (3) total reactance referred to the primary. (2)
 - (4) total reactance referred to the secondary. (2)