

Reg. No. :

--	--	--	--	--	--	--	--	--	--	--	--	--	--	--	--	--	--	--	--

Question Paper Code : 90870

B.E./B.Tech. DEGREE EXAMINATIONS, NOVEMBER/DECEMBER 2022.

Fifth/Sixth Semester

Mechanical Engineering

ME 8694 – HYDRAULICS AND PNEUMATICS

(Common to : Manufacturing Engineering/Mechanical Engineering
(Sandwich)/Robotics and Automation)

(Regulations 2017)

Time : Three hours

Maximum : 100 marks

Answer ALL questions.

PART A — (10 × 2 = 20 marks)

1. What are the two factors responsible for the high responsiveness of hydraulic devices?
2. What are the disadvantages of variable displacement pump?
3. Draw the symbol of flow control valve and pressure reducing valve.
4. How size of reservoir is arrived?
5. What is the advantage of air over oil circuits?
6. List the ways of synchronizing two double acting cylinders.
7. What are the disadvantages of fluidics?
8. State the applications of pneumatic logic circuits.
9. What are the four criteria of design of hydraulic circuits?
10. What constitutes a power pack?

PART B — (5 × 13 = 65 marks)

11. (a) (i) A pump has a displacement volume of 98.4 cm³. It delivers 0.0152 m³/s of oil at 1000 RPM and 70 bar. If the prime mover input torque is 124.3 Nm. What is the overall efficiency of pump? What is the theoretical torque required to operate the pump? (7)
- (ii) List the desired properties of hydraulic fluid. (6)

Or

- (b) (i) Describe the working principle of variable displacement piston pump. (8)
- (ii) Find the offset angle for an axial pump that delivers 0.0019 m³/s at 3000 rpm. The pump has nine pistons with 15.9 mm diameter arranged on a 127 mm piston circle diameter. The volumetric efficiency is 95%. (5)
12. (a) Explain hydraulic cushioning in linear actuator.

Or

- (b) Explain the working principle of proportional control of valves.
13. (a) Compare speed control of actuator based on meter in, meter out and bleed off circuit.

Or

- (b) Explain the benefits and an application of Intensifier and Accumulator.
14. (a) Design pneumatic circuit for process represented in Fig. 1.

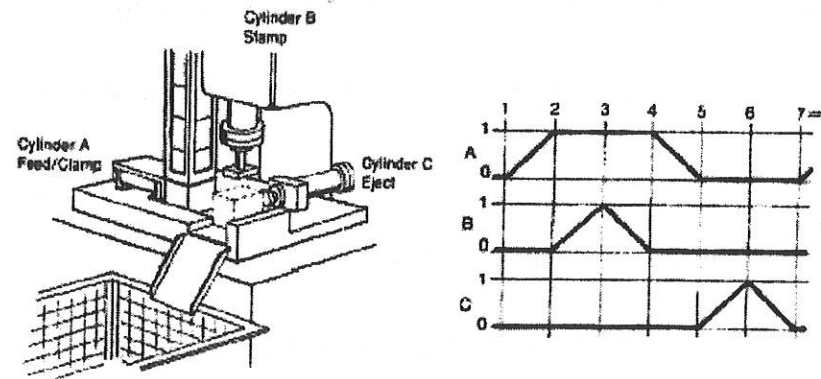

Fig. 1

Or

- (b) Comment on the selection of components in pneumatic system for riveting of sheet metal using pneumatic actuators for clamping and pressing. Illustrate with suitable circuit.

15. (a) Illustrate the hydraulic system for operation of surface grinding.

Or

- (b) Illustrate the hydraulic system for operation of press.

PART C — (1 × 15 = 15 marks)

16. (a) (i) An accumulator is to supply 7370 cm³ of oil with a maximum pressure of 210 bar and minimum pressure of 126 bar gauge to a hydraulic cylinder. If the nitrogen pre-charge pressure is 84 bars gauge, find the size of the accumulator. The hydraulic cylinder piston diameter is 152 mm. (8)
- (ii) Brief on the trouble shooting and remedies in Hydraulics. (7)

Or

- (b) (i) Consider a 100 kN press with overhanging tool with weight of 5 kN. Cylinder bore = 80 mm. Cylinder rod = 60 mm. Find the pressure to achieve 100 kN force using counter balance valve (CBV). What is the advantage of using Brake valve instead of CBV, for same application and assuming 2:1 pilot input ratio set at 23 bar to balance the tool weight. (8)

- (ii) Brief on the trouble shooting and remedies in Pneumatics. (7)