

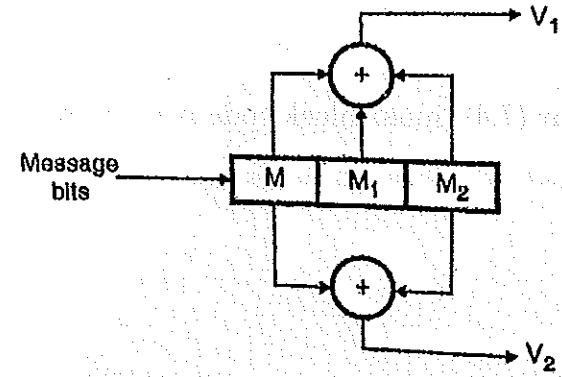

- ii) Briefly discuss the serial and parallel data transmission with necessary diagram. (6)

(OR)

- b) For the given coder shown below, obtain the convolutional code for the bit sequence 1 1 0 1 1 0 1 1 and decode it by constructing the corresponding code tree. (15)



Reg. No. :

--	--	--	--	--	--	--	--	--	--	--	--	--	--	--	--	--	--	--	--

Question Paper Code : 91395

B.E./B.Tech. DEGREE EXAMINATIONS, NOVEMBER/DECEMBER 2019

Third/Fourth Semester

Computer Science and Engineering

CS 6304 – ANALOG AND DIGITAL COMMUNICATION

(Common to B.E. Biomedical Engineering/Information Technology)

(Regulations 2013)

Time : Three Hours

Maximum : 100 Marks

Answer ALL questions

PART – A

(10×2=20 Marks)

1. Name the three types of internal noise.
2. The total power of fully modulated AM transmitter is 1KW. Calculate the power transmitted, if it is transmitted as SSB.
3. Define Minimum Shift Keying.
4. Compare BPSK over QPSK.
5. List out the standard organization of data communication.
6. Define pulse time modulation.
7. A discrete data source produces messages from a set $\{x_1, x_2, x_3, x_4\}$ where the probabilities associated with the messages are $p_1=1/4$, $p_2 = 1/8$, $p_3 = 1/8$ and $p_4 = 1/2$. Find the entropy of this source.
8. Write down the properties of cyclic codes.
9. Differentiate GSM over CDMA.
10. What is Advanced Mobile Phone System ?



PART – B

(5×13=65 Marks)

11. a) One input to a conventional AM modulator is a 500 kHz carrier with an amplitude of $20V_p$. The second input is a 10 kHz modulating signal that is sufficient amplitude to cause a change in the output wave of $\pm 7.5V_p$. Determine:
- 1) Upper and lower side frequencies.
 - 2) Modulation coefficient and percent modulation.
 - 3) Peak amplitude of the modulated carrier and the upper and lower side frequency voltages.
 - 4) Maximum and minimum amplitudes of the envelope.
 - 5) Expression for the modulated wave. (13)

(OR)

- b) i) Explain the generation of SSB-SC signal using phase shift method with necessary diagram. (7)
 - ii) Describe the relationship between instantaneous carrier frequency and modulating signal for FM. (6)
12. a) Draw the block diagram of BPSK transmitter and receiver and explain its working in detail. (13)

(OR)

- b) i) Define QAM and explain the generation of 16-QAM with necessary block diagram. (7)
 - ii) For an 8-PSK system, operating with an information bit rate of 24kbps, determine (6)
 - 1) Baud
 - 2) Minimum bandwidth
 - 3) Bandwidth efficiency.
13. a) i) Define error detection and briefly explain the four different approaches in redundancy checking. (7)
- ii) Draw the simplified block diagram of a two station data communication circuit and also describe its working in detail. (6)

(OR)

- b) i) Draw the block diagram of simplex PCM transmission system and explain its working in detail. (7)
- ii) Compare different pulse communication system namely PAM, PTM and PCM. (6)

14. a) i) State and prove the Shannon source coding theorem. (6)
- ii) Consider the following eight messages with their given probabilities. With binary code, the average message length is 3 bits. Find the average message length when Huffman coding is employed to code the messages.

$$p(m_1) = 0.14, p(m_2) = 0.22, p(m_3) = 0.26, p(m_4) = 0.12, p(m_5) = 0.08,$$

$$p(m_6) = 0.05, p(m_7) = 0.03, p(m_8) = 0.10. \quad (7)$$

(OR)

- b) The parity check matrix of a particular (7,4) linear block code is given by, (13)

$$[H] = \begin{bmatrix} 1 & 1 & 1 & 0 & 1 & 0 & 0 \\ 1 & 1 & 0 & 1 & 0 & 1 & 0 \\ 1 & 0 & 1 & 1 & 0 & 0 & 1 \end{bmatrix}$$

Find :

- 1) Find the generator matrix (G).
 - 2) List all the code vectors.
 - 3) What is the minimum distance between the code vectors ?
 - 4) How many errors can be detected ? How many can be corrected ?
15. a) i) Explain the working of Global system for mobile communication with necessary diagram in detail. (7)
- ii) Briefly discuss the frequency reuse and handoff in cellular mobile communication. (6)

(OR)

- b) Elaborate the working of uplink, transponder and downlink models of a satellite system. (13)

PART – C

(1×15=15 Marks)

16. a) i) Explain the following data communication codes with example. (3)
- 1) Baudot code (3)
 - 2) ASCII code (3)
 - 3) EBCDIC code (3)