

Reg. No.

--	--	--	--	--	--	--	--	--	--	--	--	--	--	--	--	--	--	--	--

Question Paper Code : 51441

B.E/B.Tech. DEGREE EXAMINATION, MAY/JUNE 2016

Second Semester

Electronics and Communication Engineering

EC 2151/EC 25/10144 EC 205/080290007/EE 1152 – ELECTRIC CIRCUITS AND ELECTRONIC DEVICES

(Common to Computer Science and Engineering, Biomedical Engineering, Medical Electronics Engineering and Information Technology)

(Regulations 2008/2010)

Time : Three Hours

Maximum : 100 Marks

Answer ALL questions.

PART – A (10 × 2 = 20 Marks)

1. For the circuit shown below, find the voltage across and current through 6Ω resistor. The battery voltage is 20 V.

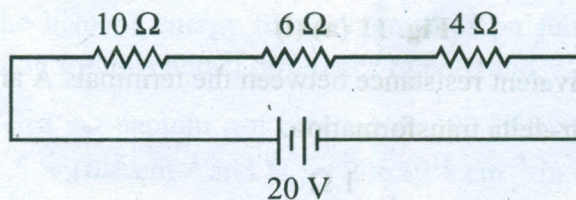

2. In the circuit shown below, what is the maximum power transferred to the load ?

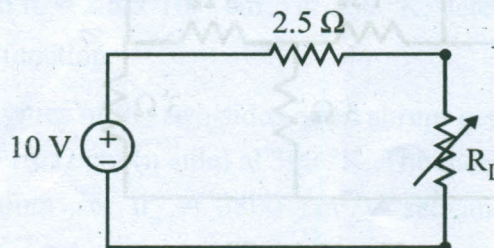

3. Write the expression for the quality factor of a resonant circuit.

4. If a coil has 500 turns linked with a flux of 50 mWb when carrying a current of 125 A, calculate the inductance of the coil.
5. Distinguish between intrinsic and extrinsic semiconductors.
6. Mention the two types of junction capacitances.
7. Define the term 'early effect'.
8. Differentiate between enhancement-type and depletion-type MOSFETs.
9. What is LED ?
10. Write the principle of operation of photodiode.

PART – B (5 × 16 = 80 Marks)

11. (a) (i) For the circuit shown in Fig 11 (a) (i), calculate the value of resistor R, when the total current taken by the network is 1.5 A. (8)

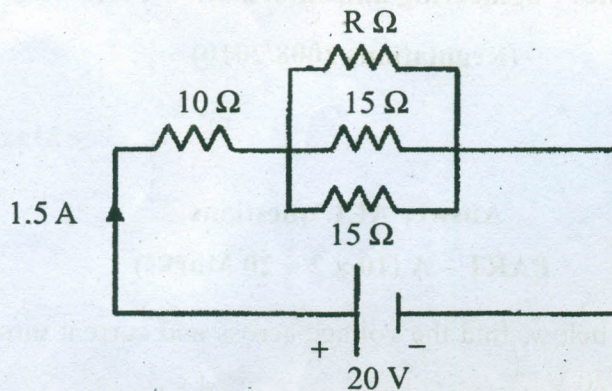

Fig. 11 (a) (i)

- (ii) Find the equivalent resistance between the terminals A and B of Fig. 11 (a) (ii), using star-delta transformation. (8)

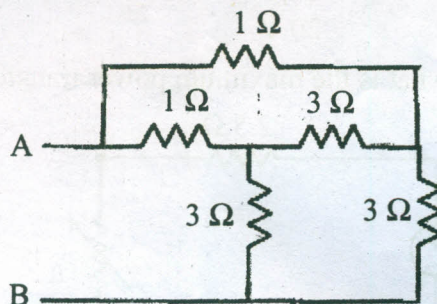

Fig. 11 (a) (ii)

OR

- (b) (i) State Thevenin's and Norton's theorems. (6)
- (ii) For the circuit shown in Fig 11 (b) (ii), determine the value of R_L to get the maximum power. Also find the maximum power transferred to the load. (10)

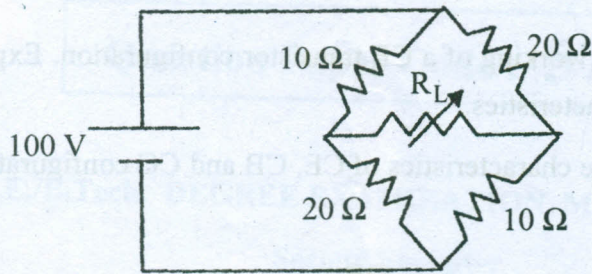

Fig. 11 (b) (ii)

12. (a) Derive an expression for the current response of RLC series circuit with sinusoidal excitation. From the results, discuss the nature of transient and steady state responses. Comment on the phase angle involved. (16)

OR

- (b) (i) Explain the concept of half power frequencies of a series RLC circuit. (4)
- (ii) A series RLC resonance circuit has $R = 100 \Omega$, $L = 0.5 \text{ H}$, $C = 0.4 \mu\text{F}$. Find the resonant frequency, the half power frequencies and the bandwidth. (4)
- (iii) Derive the quality factor of a parallel RLC circuit at resonance. (8)
13. (a) (i) With the help of energy band diagram of pn junction diode, derive the expression for the contact difference of potential. (6)
- (ii) Consider a germanium p-n junction at $300 \text{ }^\circ\text{K}$ with doping concentration $N_A = 1.5 \times 10^{18} \text{ cm}^{-3}$ and $N_D = 2 \times 10^{15} \text{ cm}^{-3}$ in the p and n sides of the junction respectively. Assuming the intrinsic carrier concentration of germanium $n_i = 2.5 \times 10^{13} \text{ cm}^{-3}$ at $300 \text{ }^\circ\text{K}$, determine the contact potential across the junction. (4)
- (iii) The resistivities of the two sides of an abrupt germanium diode are $2 \Omega \text{ cm}$ (p side) and $1 \Omega \text{ cm}$ (n side) at $300 \text{ }^\circ\text{K}$. The mobility of electrons and holes in germanium are $\mu_n = 3800 \text{ cm}^2/\text{V sec}$ and $\mu_p = 1800 \text{ cm}^2/\text{V sec}$ respectively. Calculate the height E_0 of the potential-energy barrier. (6)

OR

- (b) What is meant by Diffusion Capacitance of a p-n junction diode ? Derive an expression for the Diffusion Capacitance in terms of the current and the mean life time for holes. (16)
14. (a) (i) Explain the working of a CE transistor configuration. Explain its input and output characteristics. (10)
- (ii) Compare the characteristics of CE, CB and CC configuration of transistors. (6)

OR

- (b) (i) Explain the working of n-channel enhancement MOSFET. (10)
- (ii) Compare the characteristics of BJT, JFET and MOSFET. (6)
15. (a) (i) With a neat sketch explain construction and V-I characteristics of tunnel diode. (10)
- (ii) Explain construction and operation of photoconductive cell. (6)

OR

- (b) (i) Draw and describe the principle of operation and characteristics of SCR. (8)
- (ii) Draw and explain the working and characteristics of UJT. (8)