

Reg. No. :

--	--	--	--	--	--	--	--	--	--

**Question Paper Code : 97061**

B.E./B.Tech. DEGREE EXAMINATION, NOVEMBER/DECEMBER 2014.

Third Semester

Electronics and Communication Engineering

EC 6304 — ELECTRONIC CIRCUITS — I

(Regulation 2013)

Time : Three hours

Maximum : 100 marks

Answer ALL questions.

PART A — (10 × 2 = 20 marks)

1. Find the collector and base current of circuit given in fig. 1.  
 $h_{fe} = 100, V_{BE(on)} = 0.7V.$

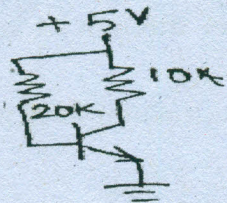

Fig.1.

2. What are the operating regions of N-Channel MOSFET and how do you identify the operating region?
3. Draw the ac equivalent circuit of figure 2.

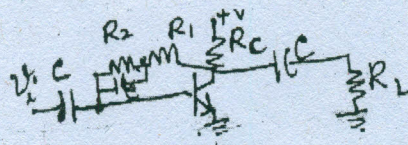

Fig.2.

4. Find CMRR of differential amplifier with differential gain of 300 and common mode gain of 0.2.

5. Draw small signal model of JFET.
6. What are the features of BiMOS cascode amplifier?
7. What is the effect of Millers capacitance on the frequency response of an amplifier?
8. Relate gain and bandwidth of single and multi-stage amplifier.
9. Draw a circuit of current source using MOSFET.
10. Draw a CMOS amplifier with NMOS driver and PMOS as active load.

PART B — (5 × 16 = 80 marks)

11. (a) (i) Design Emitter bias for BJT with  $I_c = 2mA, V_{cc} = 18V, V_{CE} = 10V$  and  $\beta = 150$ .  
(ii) Derive the stability factor of Self bias circuit of BJT.

Or

- (b) Design voltage divider bias circuit for NMOS, such that  $I_{DQ} = 400\mu A, V_{DD} = 14V, V_{DS} = 2.3V, k_n = \mu_n C_{ox}(W/L) = 1mA/V^2, V_t = 1V$ . Assume a current of  $1\mu A$  through R1 and R2, and  $V_s = 1.2V$ .

12. (a) Derive CMRR of differential amplifier with its equivalent circuit.

Or

- (b) Explain the operation of cascode amplifier and derive gain, input and output impedance.

13. (a) Derive gain, input and output impedance of common source JFET amplifier with neat circuit diagram and equivalent circuit.

Or

- (b) Derive gain, input and output impedance of MOSFET source follower with neat circuit diagram and equivalent circuit.

14. (a) (i) Derive  $f_\alpha, f_\beta$  and  $f_\gamma$ .

(ii) For the circuit shown in fig.3 find the cut-off frequencies due to  $C_1$  and  $C_2$ .

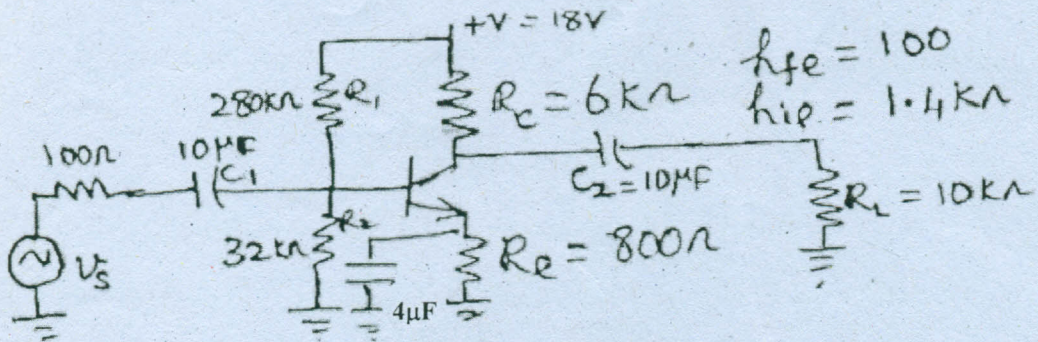

Fig.3.

Or

(b) Explain the high frequency operation of common source amplifier with its equivalent circuit.

15. (a) Draw a MOS current steering circuit with two sink and two source terminals. Write the expression for the terminal currents in terms of reference current.

Or

(b) Derive gain, input and output impedance of common source amplifier with NMOS diode connected active load.