

Reg. No.

--	--	--	--	--	--	--	--	--	--	--	--	--	--	--	--	--	--	--	--

Question Paper Code : 51504

B.E./B.Tech. DEGREE EXAMINATION, MAY/JUNE 2016

Fourth Semester

Electrical and Electronics Engineering

**EE 2254/EE 45/EC 1260/080280028/10133 EE 405 – LINEAR INTEGRATED CIRCUITS
AND APPLICATIONS**

**(Common to Instrumentation and Control Engineering and Electronics and
Instrumentation Engineering)**

(Regulations 2008/2010)

**(Also common to PTEE 2254 – Linear Integrated Circuits and Applications for B.E.
(Part-Time) – Third Semester – Electronics and Instrumentation Engineering –
Regulations 2009/10133 EE 405 – Linear Integrated Circuits and Applications for B.E.
(Part-Time) – Sixth Semester EEE – Regulations 2010)**

Time : Three Hours

Maximum : 100 Marks

Answer ALL questions.

PART – A (10 × 2 = 20 Marks)

1. List the advantages of IC's over discrete components.
2. What is the need of buried layer ?
3. Mention the ideal characteristics of an operational amplifier.
4. For the Op-Amp shown in figure 4 determine the voltage gain.

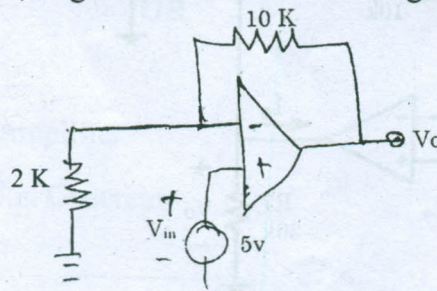
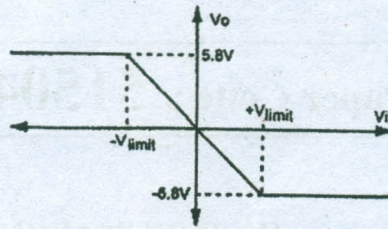

Fig. 4

5. Synthesise a circuit using Operational Amplifier to obtain the following characteristic curve. Assume the slope between the limits as unity.



6. Why integrating type ADC's are preferably used for DC and slow varying signals ?
7. Define the terms settling time and conversion time related to DAC's.
8. What is the function of a voltage regulator ?
9. Define load regulation.
10. How to define opto-coupler ?

PART - B (5 × 16 = 80 Marks)

11. (a) (i) Explain ion implant, implantation and its advantages. (6)
 (ii) Explain different types of IC packages with examples. (10)
- OR**
- (b) (i) Explain the various processing steps involved in fabrication of FET. Also draw its structural diagram. (12)
 (ii) List the merits of integrated circuits over discrete circuits. (4)

12. (a) Determine the output voltage V_o and the current I_o in the circuit as shown below :

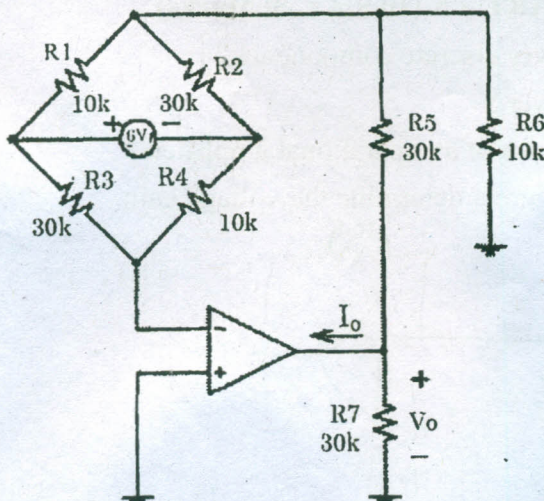

OR

- (b) Obtain the closed loop voltage gain V_0/V_i of the circuit shown below :

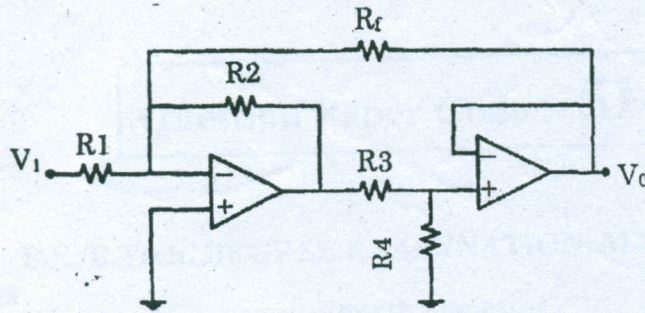

13. (a) (i) Explain the operation of peak detector and S/H circuit. (6)
 (ii) What is the use of an A/D converter ? Explain the Dual slope type of A/D converter. (10)

OR

- (b) (i) Differentiate a clipper and a clamper with neat sketches. (6)
 (ii) Explain the operation of a regenerative comparator. (10)

14. (a) Design a first order low pass filter for a high cut-off freq. of 2 KHz and pass band gain of 2.

OR

- (b) Explain the operation of a square wave generator by drawing the capacitor and output voltage wave-forms.

15. (a) Draw and explain the functional diagram of 723 general purpose regulator. (16)

OR

- (b) Write short notes on :

- (i) LM 380 Power Amplifier (8)
 (ii) ICL 8038 Function Generator (8)