

Reg. No. :

--	--	--	--	--	--	--	--	--	--	--	--	--	--	--	--	--	--	--	--

**Question Paper Code : 51438**

B.E./B.Tech. DEGREE EXAMINATION, MAY/JUNE 2014.

Fourth Semester

Electrical and Electronics Engineering

EE 2254/ EE 45/EC 1260/080280028/10133 EE 405 — LINEAR INTEGRATED  
CIRCUITS AND APPLICATIONS

(Regulation 2008/2010)

(Common to Instrumentation and Control Engineering and Electronics and  
Instrumentation Engineering)

(Common to PTEE 2254—Linear Integrated Circuits and Applications for B.E.  
(Part -Time)—Third Semester —Electronics and Instrumentation Engineering—  
Regulation 2009)

Time : Three hours

Maximum : 100 marks

Answer ALL questions.

PART A — (10 × 2 = 20 marks)

1. List out the reaction compounds and doping hydrides used in Chemical Vapour Deposition?
2. What is Ion Implantation? Why it is preferred over diffusion process?
3. Draw the frequency response characteristic of an AC Integrator and indicate the part where it behaves as a True Integrator.
4. State the causes for Slew rate in an operational amplifier? How it is indicated?
5. Synthesise a circuit using Operational Amplifier to obtain the following Characteristic curve. Assume the slope between the limits as unity.

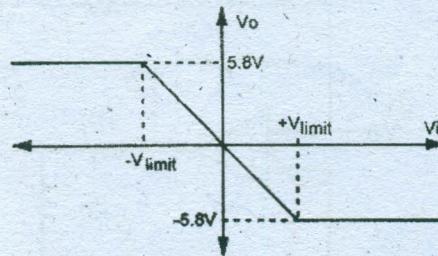

6. Why integrating type ADC's are preferably used for DC and slow varying Signals?

7. Why invariably a suitable value of capacitor is connected to the pin 5 of 555 Timer applications?
8. Draw the block diagrammatic representation of a frequency multiplier using PLL?
9. State the need for protection diodes in voltage regulators based on LM 317 regulator?
10. State the need and advantages of Isolation Amplifiers?

PART B — (5 × 16 = 80 marks)

11. (a) Describe in detail any two isolation technique used to provide isolation between various components in IC fabrication with illustrations? (8 + 8)  
Or  
(b) Explain in step by step basis, the fabrication of Planar P-N Junction Diode with neat illustrations.
12. (a) Determine the output voltage  $V_o$  and the current  $I_o$  in the circuit as shown below.

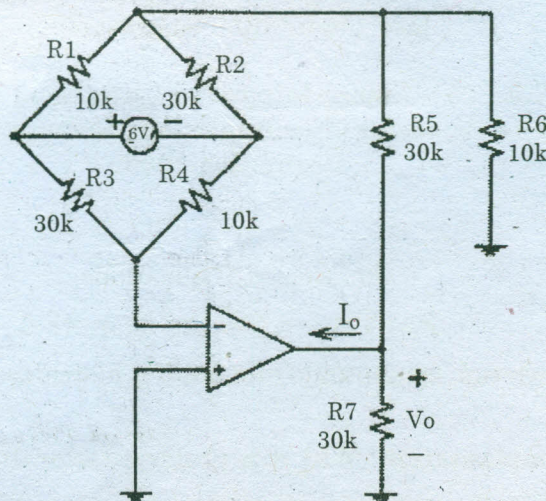

Or

- (b) Obtain the closed loop voltage gain  $V_o/V_i$  of the circuit shown below.

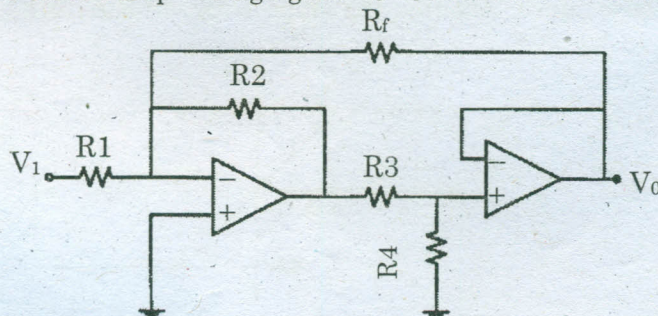

13. (a) Explain the operation of Dual slope ADC with neat illustrations? Also prove that this ADC is free from drifts? (10 + 6)

Or

- (b) With neat schematic representations explain the operation of the following circuits?
- (i) Positive Peak follower.
- (ii) Active positive clamper to clamp the input signal above ground state by 5 V. (8 + 8)
14. (a) Explain with functional block diagram the operation of 566 Voltage Controlled Oscillator. Also determine the maximum and minimum output frequencies in the circuit shown below. (10 + 6)

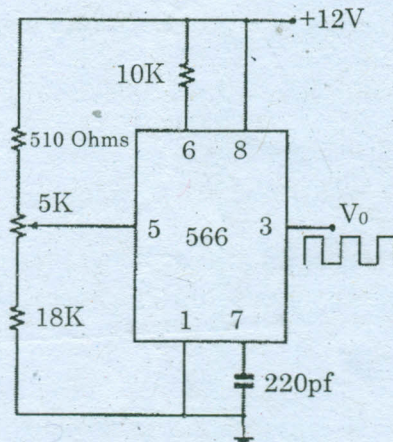

Or

- (b) Explain the operation of an astable multi-vibrator configured around 555 Timer IC and derive an expression for output frequency with neat illustration.
15. (a) Design a Voltage regulator using IC 723 regulator to satisfy the following specifications
- $V_o = 12 \text{ V}$ ,
  - $I_o = 500 \text{ mA}$ ,
  - $V_{in} = 18 \pm 20\%$ ,
  - $I_{sc} = 600 \text{ mA}$ ,
  - $V_{Sense} = 0.7 \text{ V}$ . Give the complete schematic diagram.(Assume and Justify if any data required)

Or

- (b) Discuss in detail the operation and applications of the following circuits.
- Isolation amplifier
  - Optocoupler.