

Reg. No. :

--	--	--	--	--	--	--	--	--	--	--	--	--	--	--	--	--	--	--	--

Question Paper Code : 91394

B.E./B.Tech. DEGREE EXAMINATION, NOVEMBER/DECEMBER 2014.

Second Semester

Electronics and Communication Engineering

EC 2151/EC 25/080290007/EE 1152/10144 EC 205 — ELECTRIC CIRCUITS AND ELECTRON DEVICES

(Common to Computer Science and Engineering, Biomedical Engineering, Medical Electronics Engineering and Information Technology)

(Regulation 2008/2010)

Time : Three hours

Maximum : 100 marks

Answer ALL questions.

PART A — (10 × 2 = 20 marks)

1. State the superposition theorem.
2. Write the formula for Delta to Star conversion.
3. What is the relationship between quality factor and bandwidth of a series resonant circuit?
4. Define resonance and resonant frequency of a circuit.
5. What are extrinsic semiconductors?
6. Write the total diode current equation.
7. Which transistor configuration provides both voltage gain and current gain greater than 1?
8. What is enhancement MOSFET?
9. Show the VI characteristics of a Tunnel diode.
10. State principle of operation of a photo diode.

PART B — (5 × 16 = 80 marks)

11. (a) (i) Find the Thevenin's equivalent circuit across terminals AB for the given circuit. (8)

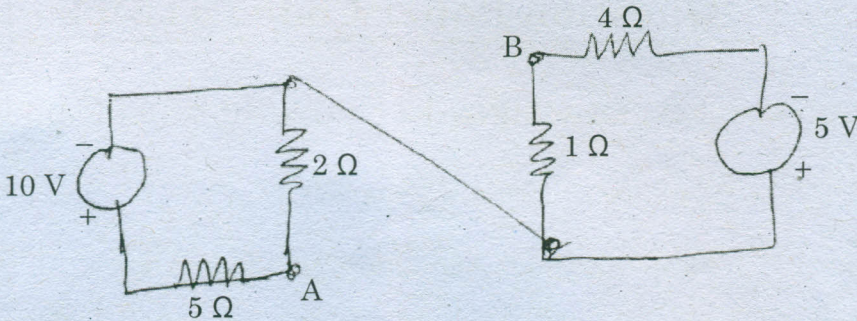

- (ii) Obtain the dual circuit for the given circuit. (8)

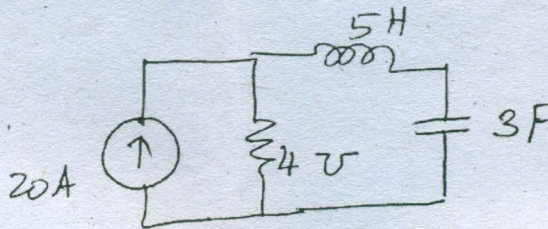

Or

- (b) For the given circuit, determine the equivalent resistance using star delta transformation. (16)

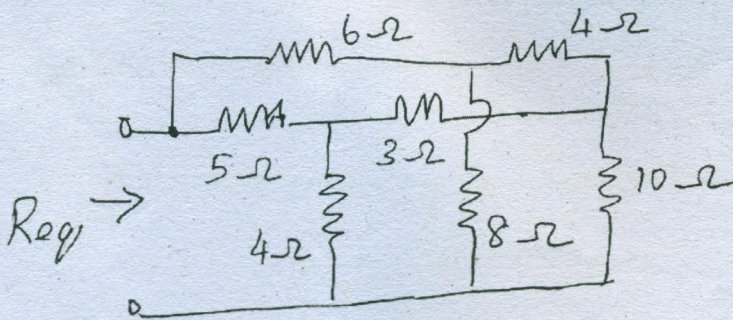

12. (a) Explain the response of RC circuit to the sinusoidal and pulse inputs in detail. (16)

Or

- (b) Discuss about single tuned and double tuned circuits. (16)

13. (a) (i) Draw the energy band diagram and explain the working of a PN junction diode. (10)
- (ii) Explain the diffusion capacitance of a diode. (6)

Or

- (b) (i) Explain the effect of temperature on PN junction diode. (8)
- (ii) Describe the breakdown in PN junction diode. (8)
14. (a) (i) Explain the operation of a PNP transistor. (8)
- (ii) Describe the Input-Output characteristics of CB transistor configuration. (8)

Or

- (b) (i) Explain the principle of operation of N channel JFET. (8)
- (ii) Explain the thermal effect on MOSFET. (8)
15. (a) Explain the structure, equivalent circuit and characteristics of SCR. (16)

Or

- (b) Explain the principle of operation of the following diodes :
- (i) PIN diode. (6)
- (ii) Laser diode. (6)
- (iii) LED diode. (4)
-