



--	--	--	--	--	--	--	--	--	--	--	--	--	--	--	--	--	--	--	--

Question Paper Code : 91479

B.E./B.Tech. DEGREE EXAMINATIONS, NOVEMBER/DECEMBER 2019

Second Semester

Electrical and Electronics Engineering

EE 6201 – CIRCUIT THEORY

(Common to : Electronics and Communication Engineering/Biomedical Engineering/
Electronics and Instrumentation Engineering/Instrumentation Control Engineering/
Medical Electronics)
(Regulations 2013)

Time : Three Hours

Maximum : 100 Marks

Answer ALL questions

PART – A

(10×2=20 Marks)

b) The following measurements were made on a two port network.

- i) With port 2 short circuited a voltage of 10V applied to port 1 results in $I_1 = 5A$ and $I_2 = -2A$.
- ii) With port 1 shorted, a voltage of 5V applied at port 2 results in $I_1 = -1A$ and $I_2 = 2A$. The reference directions of currents, I_1 and I_2 are into the network.

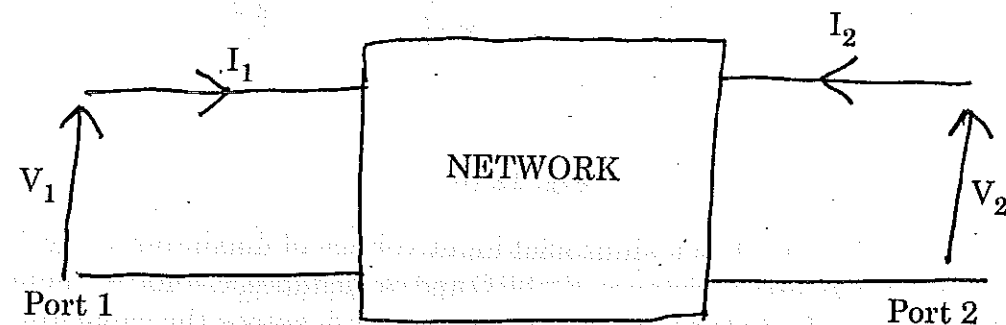

Fig. 14 (b)

Compute the Y-parameters for this network and write the Y-parameter equations. Compute the voltage across 10Ω resistor connected at port '2'.

(6+10)

15. a) Explain how power and power factor is measured using two wattmeter method.

(16)

(OR)

b) i) Find the line currents and the phase currents for the three phase delta connected circuit.

(8)

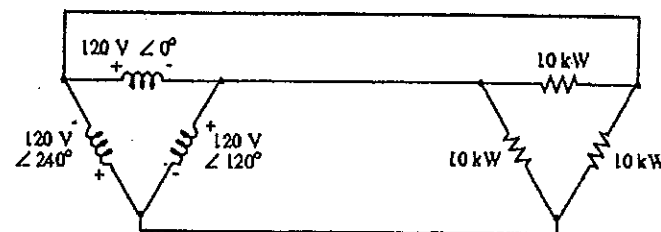

ii) List the advantages of three phase system. Discuss about three phase three wire balanced system in detail.

(8)

1. Define lumped and distributed elements in electric circuits.
2. State Kirchhoff's voltage and current law.
3. State Thevenin's theorem.
4. How can a practical voltage source, having an ideal voltage V_s and internal series resistance R_v be replaced by a current source?
5. What is a tank circuit?
6. Define bandwidth of a RLC circuit.
7. What is the time-constant for RL and RC circuits?
8. Define transmission parameters.
9. Draw the phasor diagram for a three phase star connected balanced inductive load.
10. Draw the circuit diagram to measure the three phase power using three wattmeter method.



PART - B

(5×16=80 Marks)

11. a) i) Analyse the given circuit Fig. 11 (a) and obtain the voltage across all elements, impedance, current, power factor and hence draw the phasor diagram. (13)

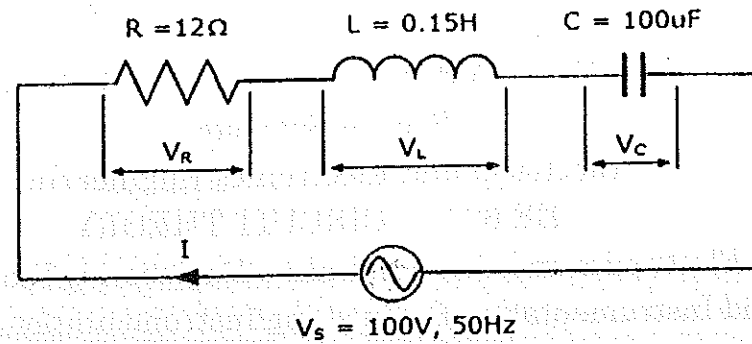

Fig. 11 (a)

- ii) Explain the significance of power factor circuit. (3)

(OR)

- b) Use nodal analysis to find the voltage at each node of this circuit. Shown in Fig. 11 (b). (16)

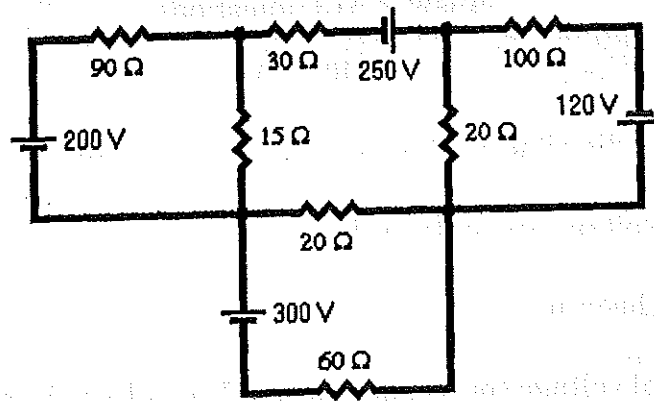

Fig. 11 (b)

12. a) Find the maximum power transferred to the load using maximum power transfer theorem for the circuit shown in Fig. 12 (a). (16)

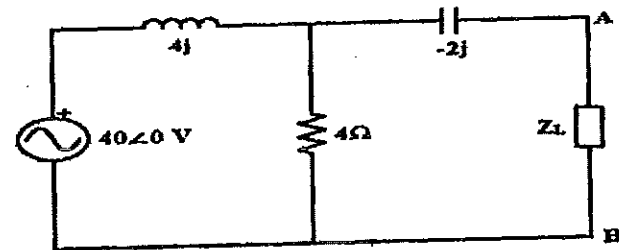

Fig. 12 (a)

(OR)



- b) Find the equivalent resistance across terminal AB in the circuit shown in Fig. 12 (b) and find the current supplied by the source. (16)

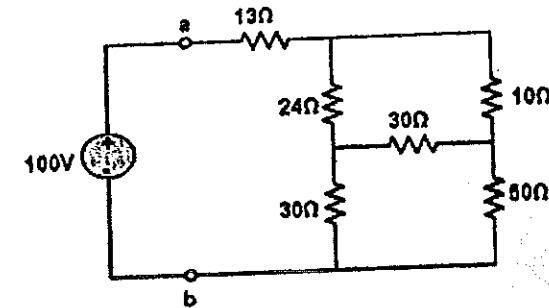

Fig. 12 (b)

13. a) A series L-R-C circuit has a sinusoidal input voltage of maximum value 12 V. If inductance, $L = 20 \text{ mH}$, resistance, $R = 80 \Omega$ and capacitance, $C = 400 \text{ nF}$, determine (a) the resonant frequency, (b) the value of the p.d. across the capacitor at the resonant frequency, (c) the frequency at which the p.d. across the capacitor is a maximum and (d) the value of the maximum voltage across the capacitor. (16)

(OR)

- b) Find the vector values of the currents in the network shown in Fig. 13 (b). Find also the power supplied by each source. (8+8)

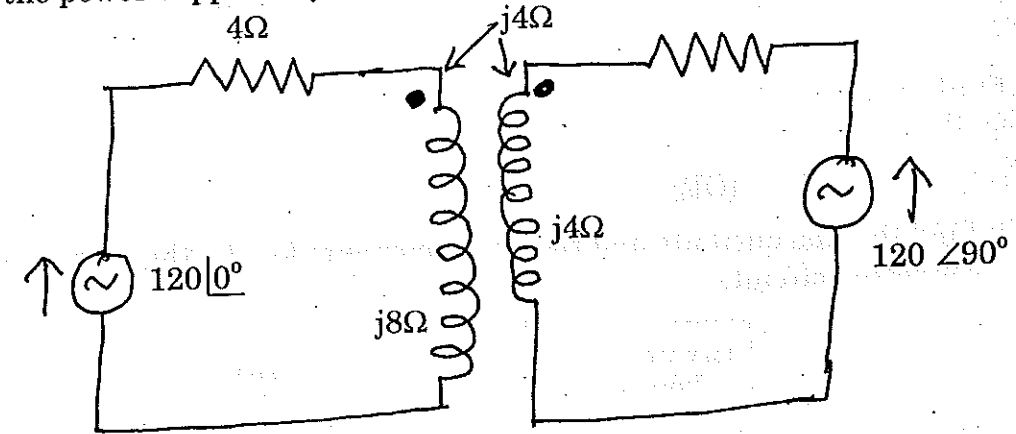

Fig. 13 (b)

14. a) A series RL circuit with $R = 100 \text{ ohms}$ and $L = 20 \text{ H}$ has a DC voltage of 200 volts applied through a switch at $t = 0$. Find :

- The equation for the current and voltages across the different elements
- The current at $t = 0.5$ seconds
- The current at 1 second and
- The time at which $e_R = e_L$.

(3+3+3+7)

(OR)