



Reg. No. :

--	--	--	--	--	--	--	--	--	--	--	--	--	--	--	--	--	--	--	--

04/11  
FN

**Question Paper Code : 50485**

**B.E./B.Tech. DEGREE EXAMINATION, NOVEMBER/DECEMBER 2017**

**Fifth Semester**

**Electrical and Electronics Engineering**

**EE 6501 – POWER SYSTEM ANALYSIS**

**(Regulations 2013)**

**Time : Three Hours**

**Maximum : 100 Marks**

**Answer ALL questions**

**PART – A**

**(10×2=20 Marks)**

1. Define per unit value of an electrical quantity and write the equation for base impedance for a three phase power system.
2. Write the equation for per unit impedance if change of base occurs.
3. What is the need for load flow analysis ?
4. Mention the various types of buses in power system with specified quantities for each bus.
5. State and explain symmetrical fault.
6. What is bolted fault or solid fault ?
7. What are the features of zero sequence current ?
8. Write down the equation to determine symmetrical components currents from unbalanced currents.
9. State equal area criterion.
10. Define transient stability of a power system.

PART - B

(5×13=65 Marks)

11. a) The single line diagram of an unloaded power system is shown in figure 11(a) along with components data determine the new per unit values and draw the reactance diagram. Assume 50 MVA and 13.8 KV as new base on generator 1. (13)

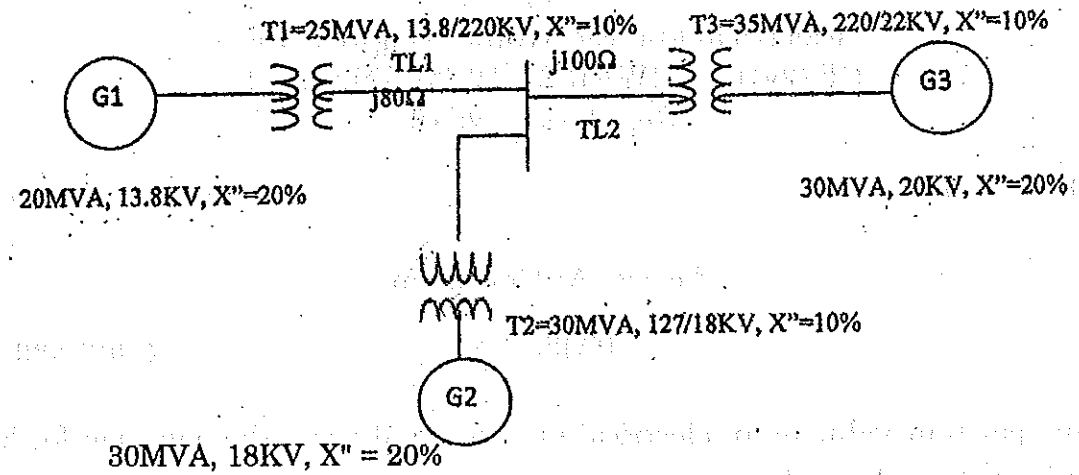

(OR)

- b) Describe the  $Z_{Bus}$  building algorithm in details by using a three bus system. (13)

12. a) With a neat flow chart, algorithm and explain the computational procedure for load flow solution using Gauss-Seidal Methods. (13)

(OR)

- b) Draw the detailed flow chart and explain the algorithm of Newton-Raphson method when the system contains all types of buses. (13)

13. a) A generating stations feeding 132 KV system is shown in Fig. 13(a). Determine the total fault current, fault level and fault current supplied by each alternator for a 3 phase solid fault at the receiving end bus. The length of the transmission line is 150 KM long. (13)

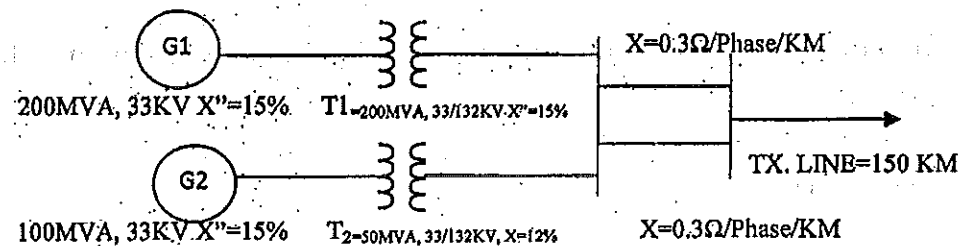

(OR)

- b) A symmetrical fault occurs at bus 4 for the system shown in fig. 13(b). Determine the fault current using  $Z_{bus}$  building algorithm. (13)

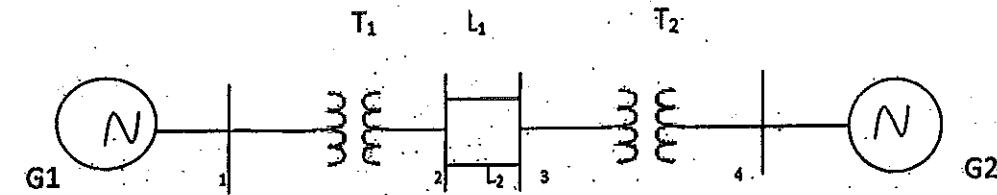

G1, G2 : 100 MVA, 20 KV,  $X'' = 15\%$  Transformers T1, T2 :  $X_{Leakage} = 9\%$   
 L1, L2 :  $X'' = 10\%$

14. a) i) What are the assumption to be made in short circuit studies? (4)  
 ii) Deduce and draw the sequence network for LLG fault at the terminal of unloaded generator. (9)

(OR)

- b) Derive the expression for fault current in line fault on unloaded generator. Draw an equivalent network showing the interconnection of networks to simulate line to ground fault. (13)

15. a) i) A generator is operating at 50 Hz, delivers 1.0 p.u. power to an infinite bus through a transmission circuit in which resistance is ignored. A fault takes place reducing the maximum power transferred to 0.5 p.u. Before the fault, the power was 2.0 p.u. and after the clearance of the fault it is 1.5 p.u. by the use of equal area criterion, determine the critical clearing angle. (8)  
 ii) Discuss the methods by which transient stability can be improved. (5)

(OR)

- b) Write the computational algorithm for obtaining swing curves using modified-Euler method. (13)

PART - C

(1×15=15 Marks)

16. a) i) Distinguish between steady state stability and dynamic stability. (8)  
 ii) Explain the importance of stability analysis in power system. (7)

(OR)

- b) Explain the term critical clearing angle and critical clearing time in connection with the transient stability of a power system. (13)