



Reg. No. :

--	--	--	--	--	--	--	--	--	--	--	--	--	--	--	--	--	--	--	--

**Question Paper Code : 41003**

B.E./B.Tech. DEGREE EXAMINATION, APRIL/MAY 2018

Fifth Semester

Electrical and Electronics Engineering  
EE 6501 – POWER SYSTEM ANALYSIS  
(Regulations 2013)

Time : Three Hours

Maximum : 100 Marks

Answer ALL questions

PART – A

(10×2=20 Marks)

1. Mention the requirements of planning the operation of a power system.
2. What is the need for base values ?
3. What is the need for slack bus in power flow analysis ?
4. Discuss the effect of acceleration factor in the load flow solution algorithm.
5. What is meant by fault calculations ?
6. What are all the assumption to be made to simplify the short circuit study ?
7. What is meant by symmetrical fault ?
8. Explain the concept of sequence impedances and sequence networks.
9. Define stability.
10. What is the significance of sub-transient reactance and transient reactance in short circuit studies ?

PART – B

(5×13=65 Marks)

11. a) i) In the single line diagram shown in figure 1, each three phase generator G is rated at 200 MVA, 13.8 kV and has reactances of 0.85 pu and are generating 1.15 pu. Transformer  $T_1$  is rated at 500 MVA, 13.5 kV/220 kV and has a reactance of 8%. The transmission line has a reactance of 7.8  $\Omega$ .

Transformer  $T_2$  has a rating of 400 MVA, 220 kV/33 kV and a reactance of 11%. The load is 250 MVA at a power factor of 0.85 lag. Convert all quantities to a common base of 500 MVA and 220 kV on the line and draw the circuit diagram with values expressed in pu. (10)

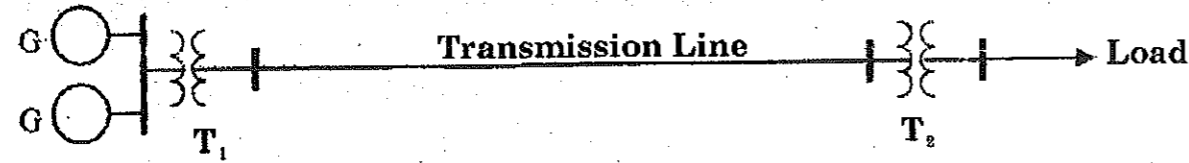

Figure 1

ii) A 200 MVA, 13.8 kV generator has a reactance of 0.85 p.u. and is generating 1.15 pu voltage. Determine the actual values of the line voltage, phase voltage and reactance. (3)

(OR)

b) Determine Z-bus for system whose reactance diagram is shown in given figure 2 where the impedance is given in p.u. preserve all the nodes. (13)

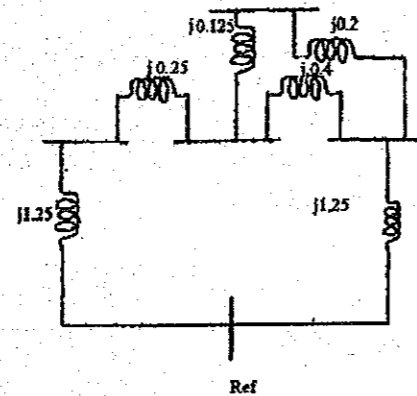

Figure 2

12. a) For the system shown in fig.3, determine the voltages at the end of the first iteration by Gauss-Seidal method. Assume base MVA as 100. (13)

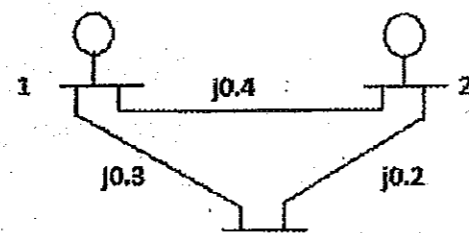

Figure 3

Bus No.	Voltage	Generator		Load		$Q_{min}$ MVAR	$Q_{max}$ MVAR
		P	Q	P	Q		
1	1.05 $\angle 0^\circ$ p.u.	-	-	-	-	-	-
2	1.02 p.u.	0.3 p.u.	-	-	-	-10	100
3	-	-	-	0.4 p.u.	0.2 p.u.	-	-

(OR)

b) Perform an iteration of Newton-Raphson load flow method and determine the power flow solution for the given system. Take base MVA as 100. (13)

Line	Bus		R(p.u.)	X(p.u.)	Half line charging admittance ( $Y_p/2$ (p.u.))
	From	To			
1	1	2	0.0839	0.5183	0.0636

Bus	$P_L$	$Q_L$
1	90	20
2	30	10

13. a) Figure shows a part of a power system, where the rest of the system at two points of coupling have been represented by their Thevenin's equivalent circuit (or by a voltage source of 1 pu together its fault level which corresponds to the per unit value of the effective Thevenin's impedance). (13)

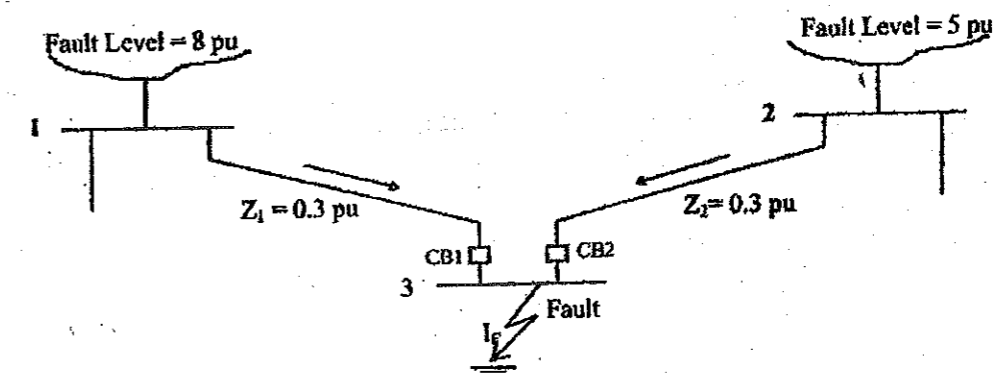

Figure 3

With CB1 and CB2 open, short circuit capacities are

SCC at bus 1 = 8 p.u. gives  $Z_{g1} = 1/8 = 0.125$  pu

SCC at bus 2 = 5 p.u. gives  $Z_{g2} = 1/5 = 0.20$  pu

Each of the lines are given to have a per unit impedance of 0.3 pu.

$Z_1 = Z_2 = 0.3$  p.u.

(OR)

- b) Explain how the fault current can be determined using  $Z_{bus}$  with neat flow chart. (13)

14. a) Brief discuss about the analysis of asymmetrical Faults in the power system with neat circuit diagrams and necessary equations. (13)

(OR)

- b) It is proposed to conduct fault analysis on two alternative configurations of the 4-bus system.

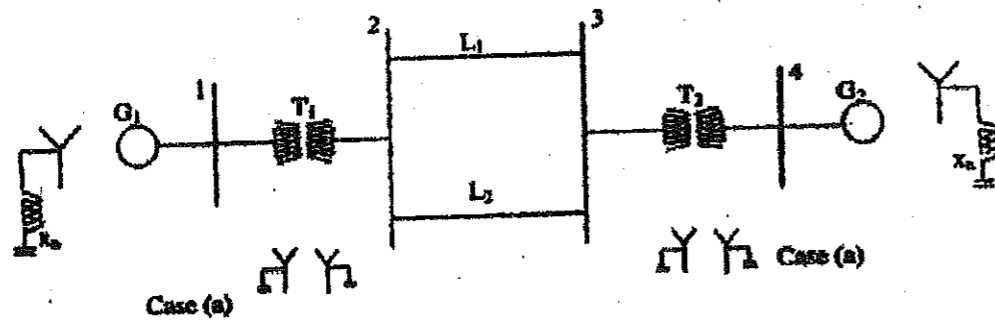

$G_1, G_2 : 100$  MVA, 20 kV,  $x^+ = x^- = x_d'' = 20\%$ ;  $x_0 = 4\%$ ;  $x_n = 5\%$ .

$T_1, T_2 : 100$  MVA, 20 kV/345 kV;  $X_{leak} = 8\%$

$L_1, L_2 : x^+ = x^- = 15\%$ ;  $x_0 = 50\%$  on a base of 100 MVA

For a three phase to ground (solid) fault at bus 4, determine the fault current and MVA at faulted bus, post fault bus voltages, fault current distribution in different elements of the network using Thevenin equivalent circuit. Draw a single-line diagram showing the above results. (13)

15. a) i) Discuss the classification of power system stability problems in the power system. (6)

- ii) Derive the swing equation of a synchronous machine swinging against an infinite bus. (7)

(OR)

- b) A 60 Hz synchronous generator having inertia constant  $H = 9.94$  MJ/MVA and a transient reactance  $X_d' = 0.3$  per unit is connected to an infinite bus through a purely reactive circuit as shown in figure. Reactances are marked on the diagram on a common system base. The generator is delivering real power of 0.6 per unit, 0.8 power factor lagging to the infinite bus at a voltage of  $V = 1$  per unit. Assume the per unit damping coefficient is  $D = 0.138$ . Consider a small disturbance of  $\Delta\delta = 10^\circ = 0.1745$  radian (the breakers open and then quickly close). (13)

- i) Obtain equations describing the motion of the rotor angle and the generator frequency.  
ii) The maximum power input that can be applied without loss of synchronism.

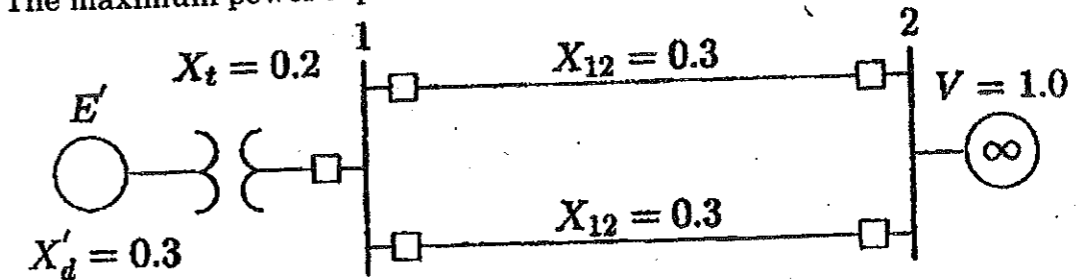

PART - C

(1×15=15 Marks)

16. Describe the importance of stability analysis of in power system planning and operation. (15)