

15. (a) A 220 V shunt motor has armature and field resistances of 0.2Ω and 220Ω respectively. The motor is driving load torque, $T_L \propto n^2$ and running at 1000 rpm drawing 10 A current from the supply. Calculate the new speed and armature current if an external armature resistance of value 5Ω is inserted in the armature circuit. Neglect armature reaction and saturation.

Or

- (b) A 220 V d.c series motor has armature and field resistances of 0.15Ω and 0.10Ω respectively. It takes a current of 30 A from the supply while running at 1000rpm. If a diverter resistance of 0.2Ω is connected across the field coil of the motor, calculate the new steady state armature current and the speed. Assume the load torque remains constant.

PART C — (1 × 15 = 15 marks)

16. (a) In the magnetic circuit detailed in Figure 16(a)-(i) with all dimensions in mm, calculate the required current to be passed in the coil having 200 turns in order to establish a flux of 1.28 mWb in the air gap. Neglect fringing effect and leakage flux. The B-H curve of the material is given in Figure 16(b)-(ii). Permeability of air may be taken as, $\mu_0 = 4\pi \times 10^{-7} H/m$.

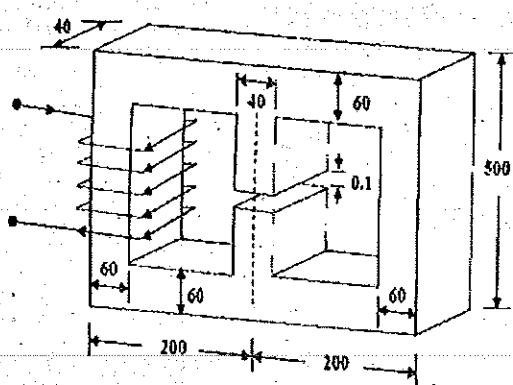

fig.16(a)-(i)

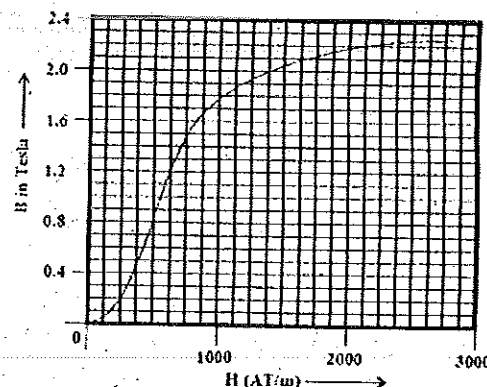

fig.16(b)-(ii)

Or

- (b) A 3-phase, 500 kVA, 6000V/400V, 50Hz, delta-star connected transformer is delivering 300 kW, at 0.8 pf lagging to a balanced 3-phase load connected to the LV side with HV side supplied from 6000 V, 3-phase supply. Calculate the line and winding currents in both the sides. Assume the transformer to be ideal.

Reg. No. :

--	--	--	--	--	--	--	--	--	--	--	--	--	--	--	--	--	--	--	--

Question Paper Code : 80125

B.E./B.Tech. DEGREE EXAMINATIONS, APRIL/MAY 2019.

Third Semester

Electrical and Electronics Engineering

EE 8301 — ELECTRICAL MACHINES – I

(Regulation 2017)

Time : Three hours

Maximum : 100 marks

Answer ALL questions.

PART A — (10 × 2 = 20 marks)

1. Write down the expression for reluctance. What is its unit?
2. Why the operating point of the magnetic systems is not selected in the saturation zone of the B-H characteristic?
3. If a transformer has 50 turns in the primary winding and 10 turns in the secondary winding, what is the reflective resistance if the secondary load resistance is 250Ω ?
4. A certain transformer has a turns ratio of 1 and a coupling coefficient of 0.85. When 2 V ac is applied to the primary, what is the secondary voltage?
5. Calculate the hourly loss of energy in kWh in a specimen of iron, the hysteresis loop of which is equivalent in area to $250 J/m^3$. Frequency 50 Hz; specific gravity of iron 7.5; weight of specimen 10 kg.
6. What are the categories of electromechanical energy conversion devices?
7. On what occasions dc generators may not have residual flux?
8. How the critical field resistance of a dc shunt generator is estimated from its OCC?
9. Enumerate the factors on which the speed of a dc motor depends.
10. How will you change the direction of rotation of a d.c motor?

PART B — (5 × 13 = 65 marks)

11. (a) A cylinder of iron or volume $8 \times 10^{-3} m^3$ revolves for 20 minutes at a speed 3000 rpm in a two pole field of flux density $0.8 \text{ Wb} \cdot m^{-2}$. If the hysteresis coefficient of iron is $753.6 \text{ joule} / m^3$, specific heat of iron is 0.11, the loss due to eddy current is equal to that due to hysteresis and 25% of the heat produced is lost by radiation, find the temperature rise of iron. Take density of iron as $7.8 \times 10^3 \text{ kg} / m^3$.

Or

- (b) The magnetic core in figure 11(b) is made from laminations of M-5 grain-oriented electrical steel. The winding is excited with a 60 Hz voltage to produce a flux density in the steel of $B = 1.5 \sin \omega t \text{ T}$, where $\omega = 2\pi 60 \text{ rad/sec}$. The steel occupies 0.94 of the core cross-sectional area. The mass-density of the steel is 7.65 g/cm^3 . Find :

- the applied voltage,
- the peak current,
- the rms exciting current, and
- the core loss.

The magnetic field intensity corresponding to $B_{\text{max}} = 1.5 \text{ T}$ is $H_{\text{max}} = 36 \text{ A turns/m}$.

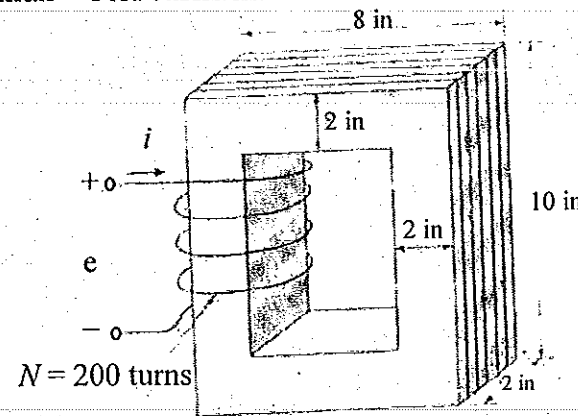

Fig.11(b)

12. (a) A 50-kVA 2400:240-V 60-Hz distribution transformer has a leakage impedance of $0.72 + j 0.92 \Omega$ in the high-voltage winding and $0.0070 + j 0.0090 \Omega$ in the low-voltage winding. At rated voltage and frequency, the impedance of the shunt branch accounting for the exciting current is $6.32 + j 43.7 \Omega$ when viewed from the low-voltage side. Draw the equivalent circuit referred to

- the high-voltage side and
- the low-voltage side, and label the impedances numerically. The transformer is used to step down the voltage at the load end of a feeder whose impedance is $0.30 + j 1.60 \Omega$. The voltage at the sending end of the feeder is 2400 V. Find the voltage at the secondary terminals of the transformer when the load connected to its secondary draws rated current from the transformer and the power factor of the load is 0.80 lagging. Neglect the voltage drops in the transformer and feeder caused by the exciting current.

Or

- (b) For the transformer of single phase, 5 kVA, 200V/400V, 50Hz, the equivalent circuit is shown in figure 12(b), calculate the following :

- the efficiency of the transformer at 75% loading with load power factor = 0.7

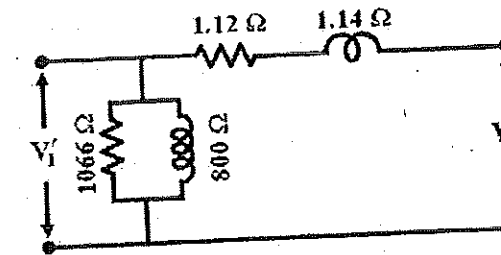

fig.12(b)

- At what load or kVA the transformer will be operated at maximum efficiency? Also calculate the value of maximum efficiency.
- The regulation of the transformer at full load 0.8 power factor lag.
- What should be the applied voltage to the LV side when the transformer delivers rated current at 0.7 power factor lagging, at a terminal voltage of 400 V?

13. (a) Sketch $L(x)$ and calculate the induced emf in the excitation coil for a linear actuator shown figures. Fig.13(a)-(i) & (ii).

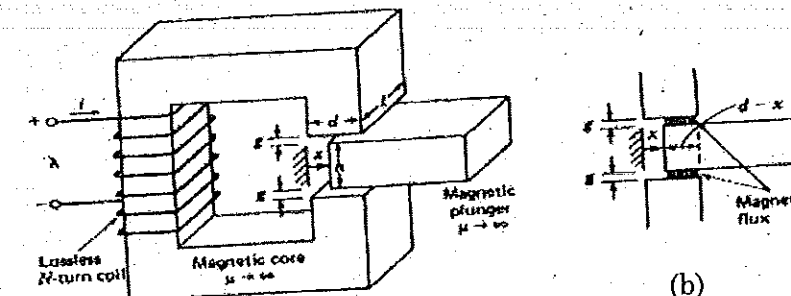

fig.13(a)-(i)

fig.13(b)-(ii)

Or

- (b) Derive Force and Torque from Energy and Co-energy for the following Electromechanical conversion systems :

- Singly Excited Linear Actuator and
- Singly Excited Rotating Actuator.

14. (a) A 200 V, d.c shunt machine has an armature resistance of 0.5Ω and field resistance of 200Ω . The machine is running at 1000 rpm as a motor drawing 31 A from the supply mains. Calculate the speed at which the machine must be driven to achieve this as generator.

Or

- (b) Derive the relation for induced emf in the dc generator from the fundamental principle.