

Reg. No. :

| | | | | | | | | | | | | | | | | | | | |
|--|--|--|--|--|--|--|--|--|--|--|--|--|--|--|--|--|--|--|--|
| | | | | | | | | | | | | | | | | | | | |
|--|--|--|--|--|--|--|--|--|--|--|--|--|--|--|--|--|--|--|--|

Question Paper Code : 20270

B.E./B.Tech. DEGREE EXAMINATION, NOVEMBER/DECEMBER 2018.

Fifth Semester

Civil Engineering

CE 6501 – STRUCTURAL ANALYSIS – I

(Regulations 2013)

(Common to PTCE 6501 – Structural Analysis – I for B.E. (Part-Time) – Third Semester – Civil Engineering – Regulations – 2014)

Time : Three hours

Maximum : 100 marks

Answer ALL questions.

PART A — (10 × 2 = 20 marks)

1. List the types of indeterminate beams.
2. State the principle of consistent deformation.
3. State Muller Breslau's principle.
4. What are the three types of connections possible with the model used with Begg's deformeter?
5. What is the degree of static indeterminacy of a three hinged parabolic arch?
6. Explain with the aid of a sketch, the normal thrust and radial shear in an arch rib.
7. State the assumptions of slope deflection equations.
8. Mention any three reasons due to which sway may occur in portal frames.
9. What is the carry over factor if the far end is hinged?
10. In a member AB, if a moment of -30 kNm is applied at A, what is the moment carried over to B, if end B is fixed?

PART B — (5 × 13 = 65 marks)

11. (a) Analyse the truss shown in fig and find the redundant reaction at C by consistent deformation method. Assuming the cross sectional area of all members are same.

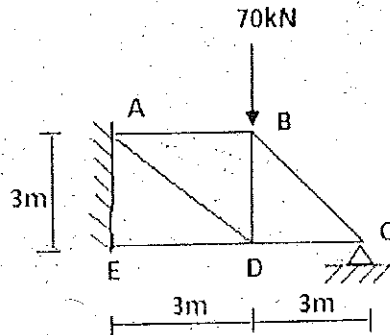

Or

- (b) Determine the reaction components by consistent deformation method in the Propped cantilever beam ABC supported at B. Span AB = 4 m, BC = 2 m. Two concentrated loads of 30 kN acts at free end C and 80 kN at 2 m from the fixed end A.

12. (a) A simply supported beam has a span of 20 m. Uniformly distributed load of 40 kN/m and 8 m long crosses the girder from left to right. Draw the influence line diagram for shear force and bending moment at a section 11 m from left end. Calculate maximum shear force and bending moment at this section.

Or

- (b) Determine the maximum forces in the members U_2U_3 and L_3U_3 of the bridge truss shown in fig if uniformly distributed load of 60 kN/m longer than the span traverses along the bottom chord members.

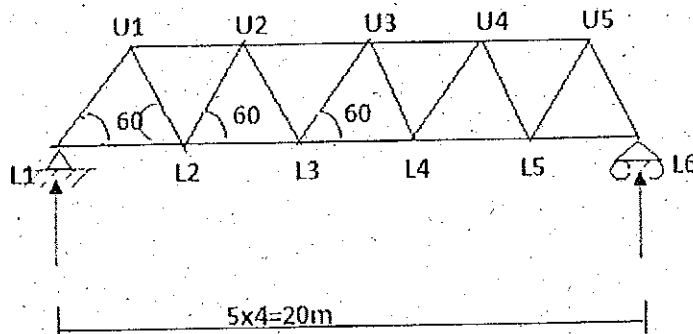

13. (a) A three hinged arch of span 50 m and rise 10 m carries an uniformly distributed load of 40 kN/m on the left half of the span and 150 kN at 25 m from right end. Find the horizontal thrust.

Or

- (b) A symmetrical three hinged parabolic arch of span 40m and rise 10 m carries an uniformly distributed load of 30 kN/m over the left half of the span. Calculate the reactions at the supports. Calculate the bending moment, radial shear and normal thrust at 15m from left support.

14. (a) Analyse the beam by the slope deflection method and draw the BMD. A beam ABCD is fixed at A and D and simply supported at B and C. Span AB = 6 m, BC = 6 m, CD = 6 m, subjected to uniformly distributed load of 30 kN/m over entire span.

Or

- (b) Analyse the portal frame shown in fig by the slope deflection method and draw BMD.

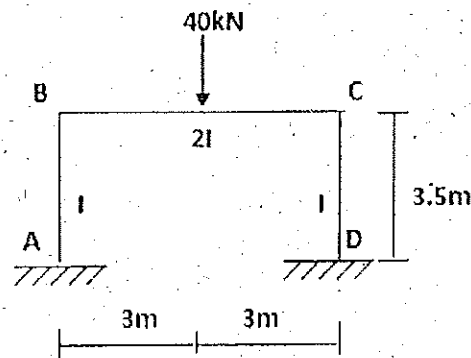

15. (a) Determine the final moments in the continuous beam ABC subjected to 40 kN at 2 m from A and uniformly distributed load of 35 kN/m over the whole span BC. Span AB = 6 m, BC = 5 m. I is uniform. Use moment distribution method.

Or

- (b) Determine the final moments in the beam ABC supported by the column BD and is loaded as shown in fig. Use moment distribution method.

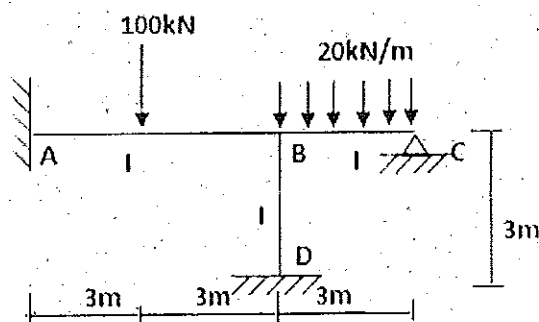

PART C — (1 × 15 = 15 marks)

16. (a) Analyse the continuous beam ABCD by slope deflection method and find the end moments. Support B sinks by 10 mm. $E = 2 \times 10^5 \text{ N/mm}^2$ and $I = 16 \times 10^7 \text{ mm}^4$.

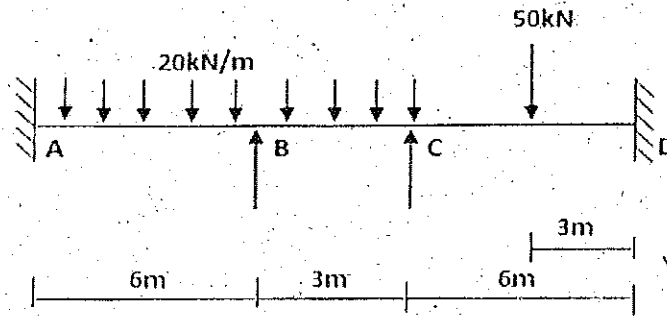

Or

- (b) Analyse the continuous beam loaded as shown in fig. by moment distribution method and find final moments.

