

Reg. No. :

--	--	--	--	--	--	--	--	--	--	--	--	--	--	--	--	--	--	--	--

Question Paper Code : 20277

B.E./B.Tech. DEGREE EXAMINATION, NOVEMBER/DECEMBER 2018.

Fifth/Sixth Semester

Civil Engineering

CE 6601 – DESIGN OF REINFORCED CONCRETE AND BRICK MASONRY
STRUCTURES'

(Regulations 2013)

Time : Three hours

Maximum : 100 marks

Use of IS 456-2000 and SP 16 is permitted.

Answer ALL questions.

PART A — (10 × 2 = 20 marks)

1. List the types of retaining wall.
2. Rewrite angle of internal friction.
3. List the types of water tanks.
4. Mention the types of joints used in water tanks.
5. Reproduce the technical terms used in a staircase.
6. Write the purpose to use waffle slab.
7. Name the methods of yield line analysis.
8. What is meant by a fracture line?
9. Name the multiplying factors used in brick masonry analysis.
10. List the types of masonry walls used in building construction.

PART B — (5 × 13 = 65 marks)

11. (a) Design a stem of a reinforced concrete T — shaped retaining wall to retain 4.5 m high earth with a horizontal surface at the top. The retained soil is well drained medium dense sand of unit weight of 16.5 kN/m³ and angle of repose of 30°. The material under the wall base is the same as above with a safe bearing capacity of 160 kN/m². The coefficient of friction between the base and the soil is 0.55. The grades of concrete and steel to be used are M20 and Fe415 respectively.

Or

- (b) Analyze the stability of a counterfort retaining wall to the following particulars.

Height of the wall above the general ground level = 5.75 m

Safe bearing capacity of the soil = 180 kN/m²

Angle of repose of the soil = 30°, Weight of soil = 16500 N/m³, Use M20 concrete and Fe 415 steel.

12. (a) Figure shows the arrangement for a circular overhead tank supported on four columns. Design the tank.

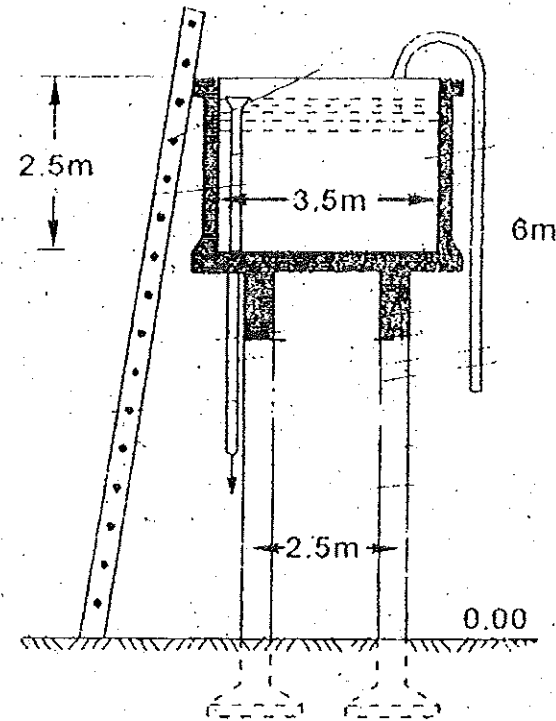

Or

- (b) Design the wall thickness and the roof slab of an underground tank of internal dimensions 12 m × 3.5 m × 3.5 m. The soil weighs 18000 N/m³. Use M25 concrete and Fe 415 steel.

Conditions:

- (i) Tank is full and the surrounding soil is dry
(ii) Tank is empty and the surrounding soil is water — logged.

13. (a) Summarize the design principles of mat foundation and road bridge.

Or

- (b) Design a single stair to reach a roof slab at a height of 2.5 m. Rise and thread of the steps may be taken as 200 mm and 250 mm respectively. The stairs shall be 1.2 m wide. Use M20 concrete and Fe 415 steel.

14. (a) Design a isotropically reinforced concrete slab of size 5.25 m × 4.50 m which is free on one of the shorter sides and continuous on the remaining three, for a live load of 2 kN/m² and finish load of 0.7 kN/m². The materials to be used are M20 concrete and HYSD steel of grade Fe 415. The environmental exposure may be taken to be mild. Adopt $k = 1.32$.

Or

- (b) An isotropically reinforced equilateral triangular slab is subjected to uniformly distributed load W_u per unit area. Any restraining moment is equal to positive moment. Calculate ultimate load when the slab is (i) simply supported on all the three edges, (ii) fixed on one edge, (iii) fixed on two edges, (iv) completely fixed on all edges.

15. (a) Resolve an interior cross wall of two story building to carry 130 mm thick R.C.C slab with 3 m ceiling height. The wall is stiff and it support 2.55 m wide slab. The live load on roof and floor is 1.55 kN/m² and 2 kN/m². Adopt crushing strength 10 MPa mortar M₁.

Or

- (b) Design an exterior wall of two storied building using nominal bricks of 230 × 100 × 75 mm. The wall supports R.C.C roof slab of 125 mm thick. Clear height of each floor is 3 m. Center to center distance between cross wall is 2.5 m and continuous along one direction only, effective width of slab supported by the wall is 1.5 m. Live load from roof slab is 1.5 N/m² and live load from slab is 2.5 N/m².

PART C — (1 × 15 = 15 marks)

16. (a) A flat slab floor system consisting of six panels of six panels in each direction supports dead and live loads of 7.5 kN/m² and 6.25 kN/m², respectively. The supporting columns are of 550 mm diameter with storey height of 3 m. Design an interior panel of size of 5.7 m × 6.5 m using the provisions of IS : 456 for the direct design method when n column head or drop is provided. The materials used are M25 concrete and HYSD steel of grade Fe 415.

Or

- (b) The main stair of an office building has to be located in a stair measuring 3 m × 5 m. The vertical distance between the floors is 3 m. Design the stairs. Allow a live load of 2000 N/m². Use M20. Concrete and Fe415 steel.