



Reg. No. :

--	--	--	--	--	--	--	--	--	--	--	--

Question Paper Code : X 10253

B.E./B.Tech. DEGREE EXAMINATIONS, NOVEMBER/DECEMBER 2020
Seventh Semester
Civil Engineering
CE 8701 – ESTIMATION, COSTING AND VALUATION ENGINEERING
(Regulations 2017)

Time : Three Hours

Maximum : 100 Marks

Answer ALL questions.

PART – A

(10×2=20 Marks)

1. Define the term estimation and list its types.
2. Compute the quantity of cement and sand required for 100 m³ of brick masonry work with 1:6 cement mortar.
3. What is the purpose of doing rate analysis ?
4. Describe schedule of rates.
5. Define specifications and mention its purpose.
6. Write how general specification for a class of building differs from detailed specification.
7. Write two features of departmental and contractual systems of executing works.
8. Define contracts, mention two of its legal implications.
9. What is known as Earnest money deposit ?
10. Mention the various methods of valuation.

PART – B

(5×13=65 Marks)

11. a) Briefly explain the different types of estimates and discuss at which situation each type is preferred by giving appropriate justification.

(OR)

- b) For the building shown in fig. 1. Determine the quantities of the following items of work. Sand filling in plinth, RCC work in slabs and beams, I class brickwork in foundation and plinth.



12. a) Arrive at the rate/cum of the following item of work of lime concrete in terraced roof (1:3:6) with 25 mm gauge brick ballast with lime and Surkhi 1:3 proportion.

Labour requirement : For 10 cum of lime concrete in roof terrace.

Mason 1st class – ½ no. @ Rs. 550/day

Mason 2nd class – 2 no. @ Rs. 500/day

Mazdoor 1st class – 10 nos. @ Rs. 450/day

Mazdoor 2nd class – 25 nos. @ Rs. 350/day

Coolie – 3 nos. @ Rs. 300/day

Cost of materials

Brick Ballast I – Class (25mm gauge) – Rs. 4000/cum

White lime slaked – Rs. 5000/cum

Surkhi – Rs. 2500/cum

Molasses – Rs. 25/kg.

Bail fruit – Take lumpsum Rs. 500.

(OR)

- b) Half brick wall (10 cm thick as partition wall) with 1:4 cement mortar – Arrive at rate/sq.m.

Labour requirement : For 100 sq.m. area of ½ brick wall.

Mason 1st class – ½ no. @ Rs. 550/day

Mason 2nd class – 12 no. @ Rs. 500/day

Mazdoor 1st class – 8 nos. @ Rs. 450/day

Mazdoor 2nd class – 10 nos. @ Rs. 350/day

Coolie – 2 nos. @ Rs. 300/day

Cost of materials :

Brick 1st class – Rs 6.50/no.

Cement – per bag – Rs. 400/-

Sand coarse – per cum – Rs. 3,500/-

Mild steel bars @ 6mm diameter – per tonne – Rs. 40,000/-



13. a) Discuss the detailed specifications for 1st class brickwork in buildings mentioning its salient features.

(OR)

b) Explain the features and significance of 'estimate report' for a building.

14. a) Explain briefly the procedure of selecting a contractor through inviting open tenders to carry out a project costing Rs. 50 lakhs.

(OR)

b) Write a note on : penalties and arbitration in projects.

15. a) i) What is the linear method of calculating depreciation ? (6)

ii) Age of the building is 10 years. Rate of depreciation is assumed as 15%.
What is the depreciation of the building ? (7)

(OR)

b) i) What are the different methods of valuation ? (6)

ii) What are the normal lives of different types of building ? (7)

PART – C

(1×15=15 Marks)

16. a) Estimate the quantities of the following items for the building giving in Fig. 1.

i) Brick work in super structure

ii) Material in floor

iii) Material in roof

iv) Exterior plastering and Interior plastering.

(OR)

b) Estimate the quantities of the following items of works for the building as shown in fig. 1.

i) Earthwork in excavation in foundation

ii) PCC in foundation

iii) Stone masonry in footings and plinth

iv) Material in Damp proof course of 2.5 cm thickness

v) Material in steps.

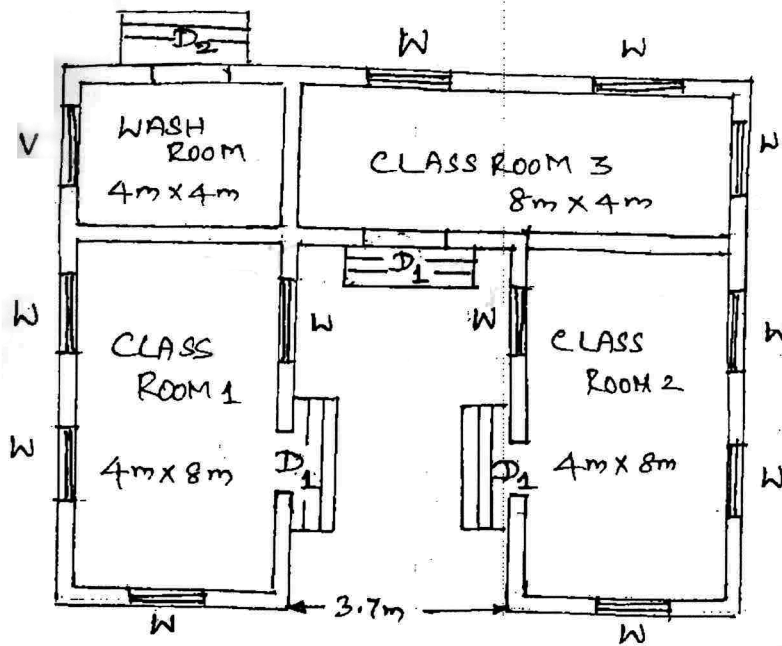

Assume

- $D_1 = 1.5\text{m} \times 2.1\text{m}$
- $D_2 = 1.0\text{m} \times 2.1\text{m}$
- $W = 1.5\text{m} \times 1.8\text{m}$
- $V = 1.5\text{m} \times 0.5\text{m}$

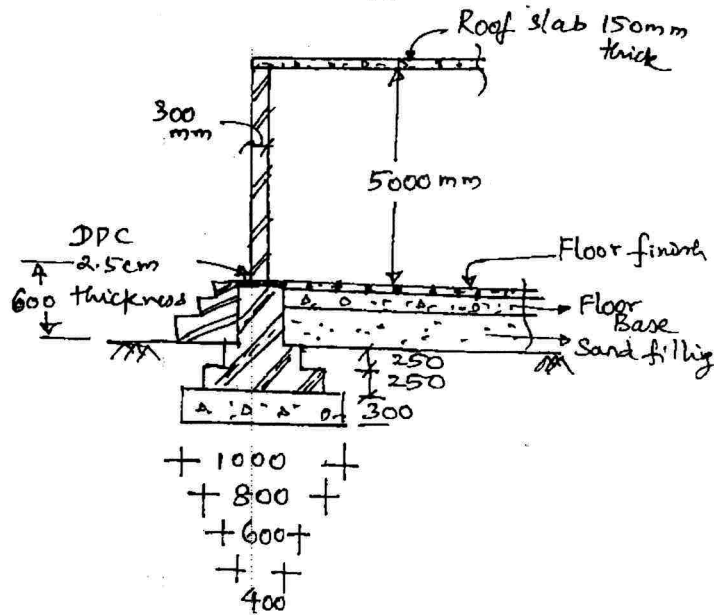

All Dimensions are in mm

Figure 1